

32374

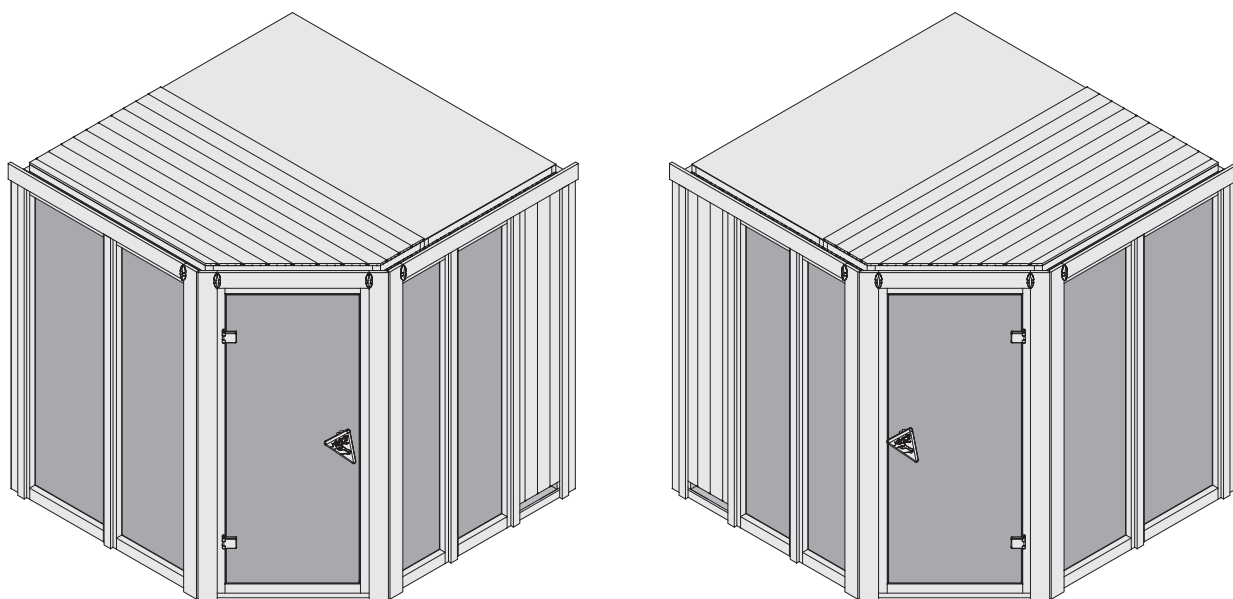

 **Aufbauanleitung**

 **Building Instructions**

 **notice de montage**

 **montagehandleiding**

 **Montagevejledning**

 **Instrucciones de construcción**

 **Istruzioni per il montaggio**

 **Montážní návod**

 **Navodila za sestavljanje**

Bitte bewahren Sie die Anleitung und den Garantieschein zur Seriennummer auf.

Vernichten Sie diese erst nach Ablauf der Garantiezeit.

Eventuelle Beanstandungen können mithilfe der Stückliste einfacher zugeordnet werden.

Beigelegte Dokumente

- Informationsheft
- Garantieschein zur Seriennummer
- Typenschild inkl. Warnhinweise (Sauna)
- ggf. Zubehör-Anleitungen in externen Paketen

*

 Nicht im Lieferumfang enthalten

 Not included

 Non comprises dans la livraison

 Niet bijgeleverd

 No forman parte del suministro

 Non incluso

 V ceně není zahrnuto

 Ikke inkluderet

 Ni vključeno v obseg dobave

2

 Nicht gebraucht

 Not needed

 Pas nécessaire

 Niet nodig

 No es necesario

 Non necessario

 Není nutná

 Ikke nødvendigt

 Ne uporablja se

4

 Fixiert vorübergehend

 Fixed temporarily

 Temporairement fixe

 Tijdelijk vast

 Temporalmente fijo

 Temporaneamente fisso

 Dočasně pevný

 Midlertidigt rettet

 Začasno popravi

1

 Länge muss ermittelt und zugesägt werden

 Length must be determined and sawn

 La longueur doit être déterminée et sciée

 De lengte moet worden bepaald en worden gezaagd

 La longitud debe ser determinada y aserrada

 La lunghezza deve essere determinata e segata

 Délka musí být určena a rozřezána

 Længden skal bestemmes og saves

 Določiti je treba dolžino in jo odrezati po velikosti.

3

 Mit Zubehör

 With accessories

 Avec accessoires

 Met toebehoren

 Con accesorios

 Con accessori

 S příslušenstvím

 Med tilbehør

 Z dodatki

5

 Bestand vom Haus

 Inventory of the house

 Inventaire de la maison

 Inventaris von het huis

 Inventario de la casa

 Inventario della casa

 Inventář domu

 Inventar af huset

 Inventarizacija hiše

 Vergleichen Sie zuerst die Material-liste mit Ihrem Paketinhalt! Bitte haben Sie Verständnis, dass Beanstandungen nur im nicht aufgebauten Zustand bearbeitet werden können!

 First compare the list of materials with your package contents! Please understand that complaints can be processed in the non-built status only!

 Commencez par comparer la liste du matériel avec le contenu de votre paquet! Sachez que nous traitons uniquement les réclamations concernant le matériel à l'état non monté!

 Vergelijk eerst de lijst van materialen met de inhoud van uw pakket! Reclamaties kunnen alleen in behandeling worden genomen zolang de onderdelen nog niet zijn gemonteerd!

 Start med at kontrollere materialelisten med indholdet af den leverede pakke! Vi gør venligst opmærksom på at reklamationer kun kan behandles for materialer som ikke er blevet bearbejdet!

 En primer lugar, compare la lista de material con el contenido del paquete. Rogamos entienda que las reclamaciones sólo pueden ser tramitadas antes de montar el objeto!

 Confrontate questa distinta materiali prima con il contenuto del pacchetto! Vi preghiamo di comprendere che eventuali reclami possono essere accolti solo prima del montaggio!

 Nejprve přezkontrolujte obsah balení podle materiálového listu! Mějte pochopení pro to, že případnou reklamaci se můžeme zabývat pouze tehdy, když díly nebudou smontované! Za pomoci tohoto seznamu můžete jednotlivé díly přiřadit k montážnímu návodu.

 Najprej primerajte zoznam materialov z vsebino vašega paketa! Upoštevajte, da lahko pritožbe obravnavamo le v neseštvljenem stanju!

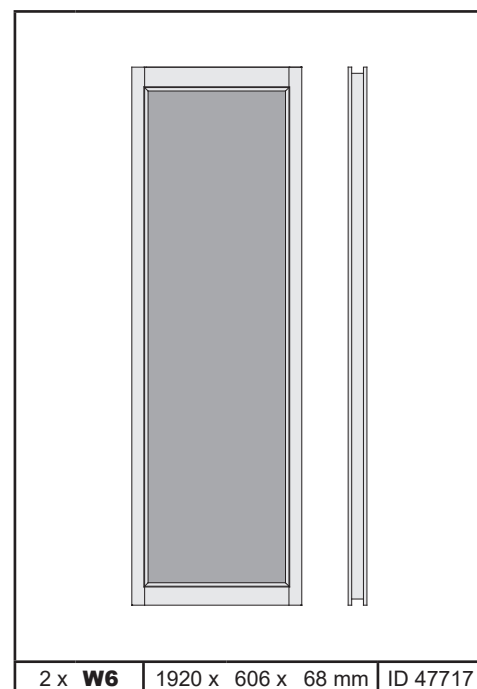
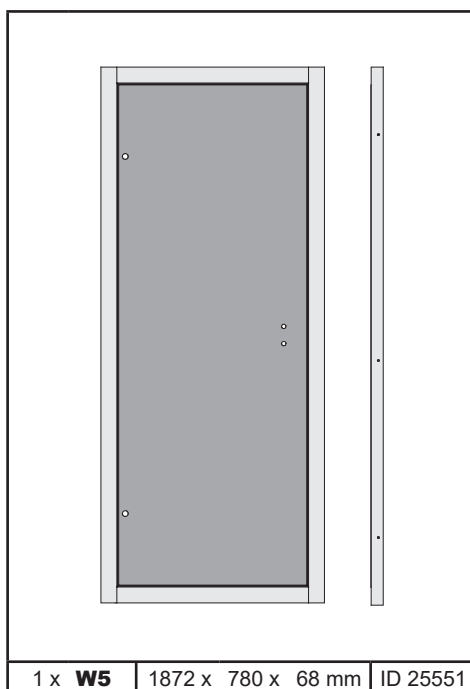
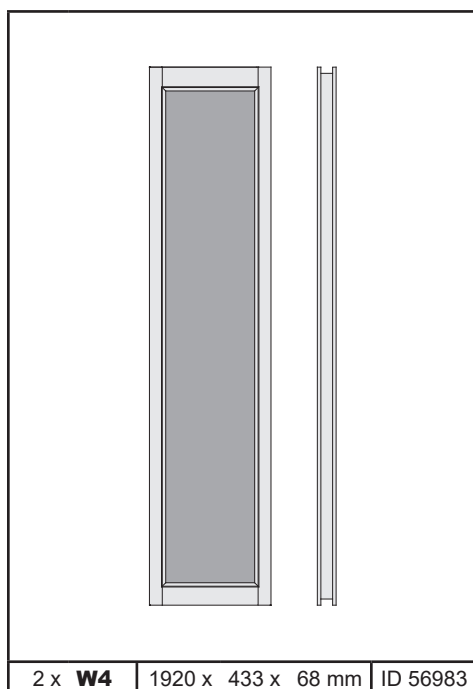
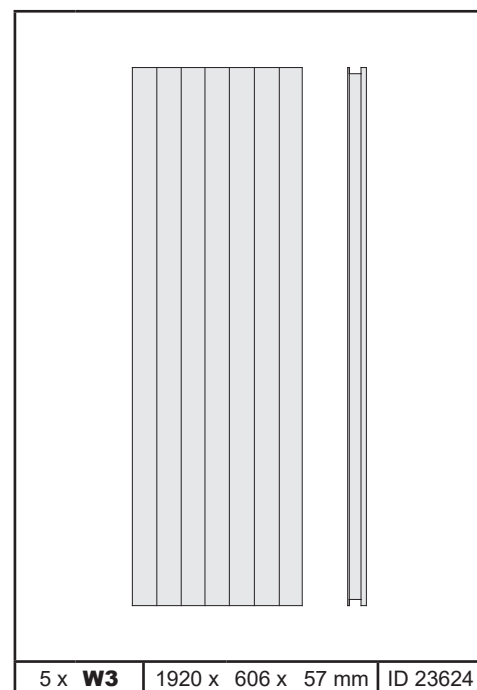
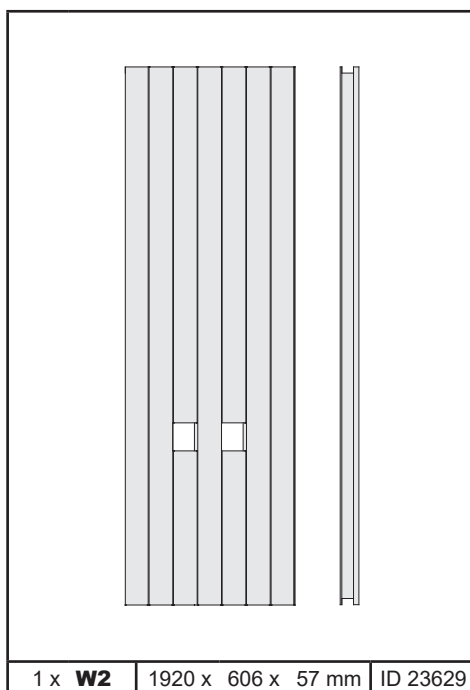
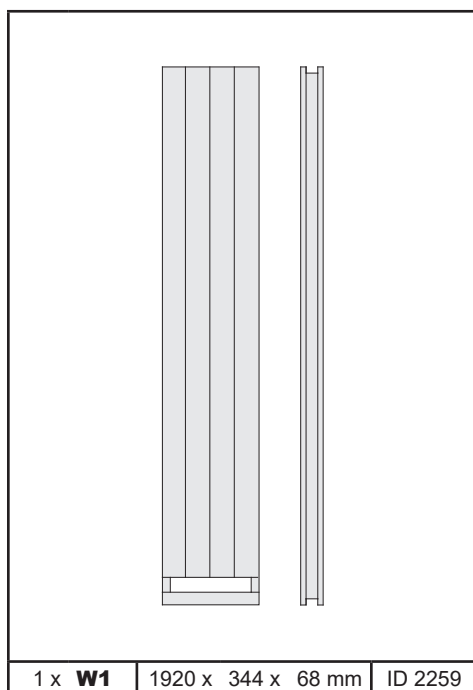
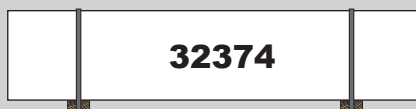

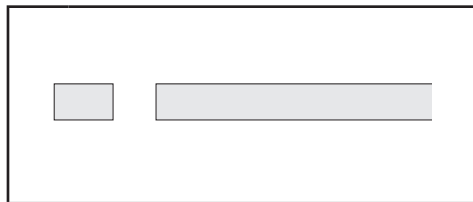

8 x B1	1920 x 19 x 3 mm	ID 20799
3 x B2	1309 x 90 x 16 mm	ID 72925
2 x B3	800 x 45 x 18 mm	ID 24796
5 x B4	1884 x 45 x 18 mm	ID 48037
3 x B5	314 x 95 x 18 mm	ID 81102
1 x B6	765 x 95 x 18 mm	ID 26357
2 x B7	1260 x 95 x 18 mm	ID 28683
1 x B8	300 x 120 x 18 mm	ID 22467
1 x B9	590 x 42 x 28 mm	ID 26360
1 x B10	1759 x 42 x 28 mm	ID 24133
1 x B11	1815 x 42 x 28 mm	ID 24098
2 x B12	1841 x 42 x 28 mm	ID 26376
2 x B13	1925 x 42 x 28 mm	ID 26382
3 x B14	1874 x 52 x 52 mm	ID 26165

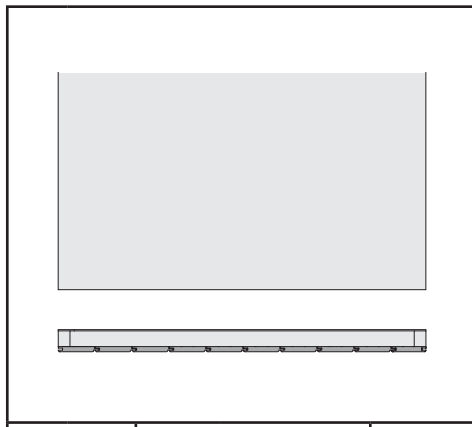

1 x M1	1839 x 918 x 57 mm	ID 45230
---------------	--------------------	----------

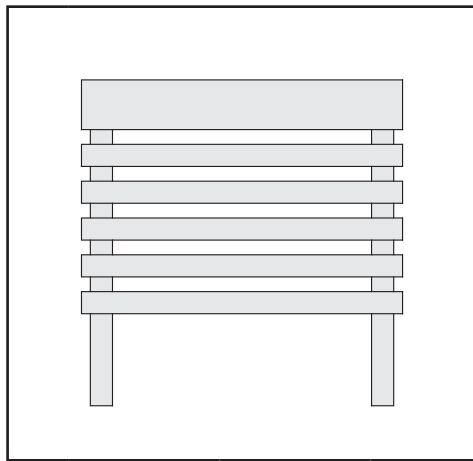

2 x Q1	474 x 630 x 32 mm	ID 2252
2 x Q2	580 x 630 x 32 mm	ID 2253

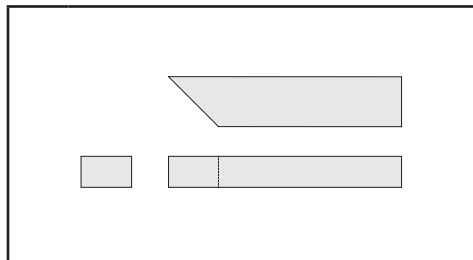

1 x C1	1181 x 42 x 28 mm	ID 56627
1 x C2	1209 x 42 x 28 mm	ID 56626
2 x C3	1247 x 42 x 28 mm	ID 25740
2 x C4	1292 x 42 x 28 mm	ID 56306

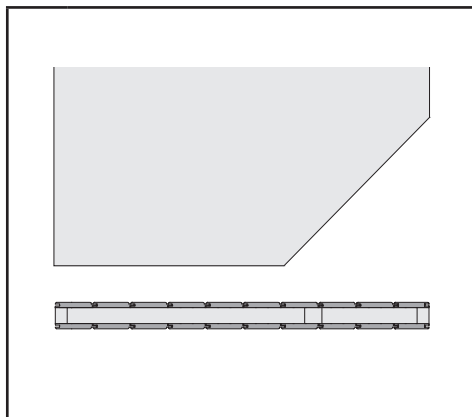

1 x M2	1839 x 918 x 68 mm	ID 52839
---------------	--------------------	----------

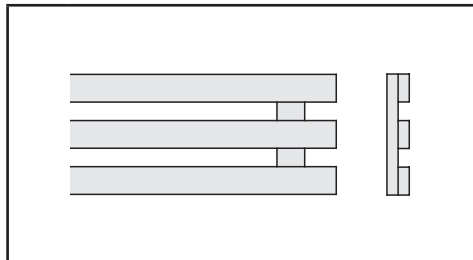

1 x Q3	478 x 174 x 32 mm	ID 13890
2 x Q4	528 x 174 x 32 mm	ID 6917
1 x Q5	1227 x 174 x 32 mm	ID 2258
4 x Q6	1305 x 174 x 32 mm	ID 13892

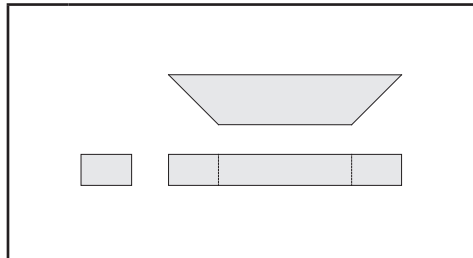

1 x C5	859 x 42 x 28 mm	ID 56308
2 x C6	896 x 42 x 28 mm	ID 56307

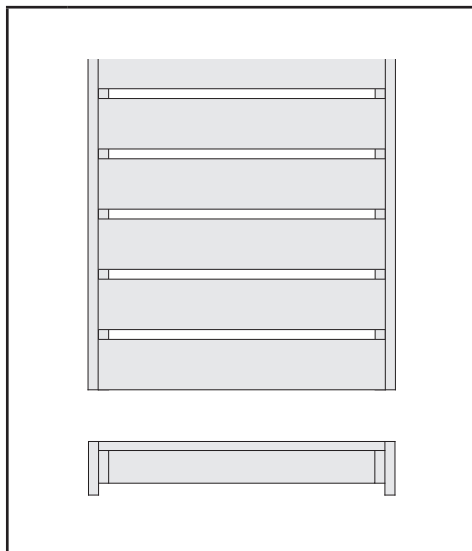

1 x L1	1260 x 500 x 90 mm	ID 23399
1 x L2	1260 x 550 x 90 mm	ID 52062
1 x L3	1810 x 550 x 90 mm	ID 21767

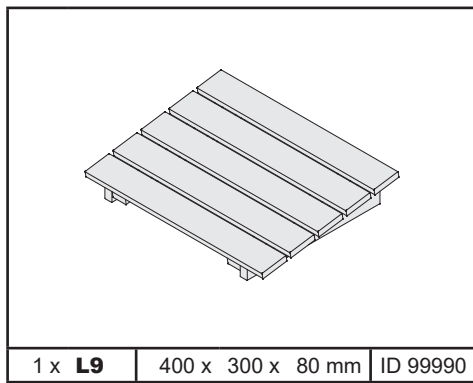

1 x L9	400 x 300 x 80 mm	ID 99990
---------------	-------------------	----------

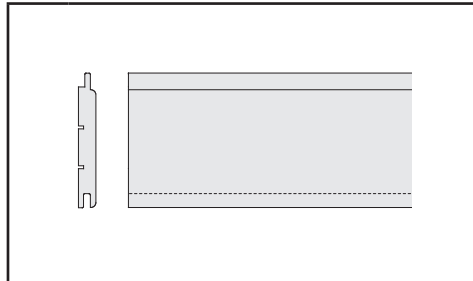

2 x E1	1920 x 97 x 12 mm	ID 22863
---------------	-------------------	----------

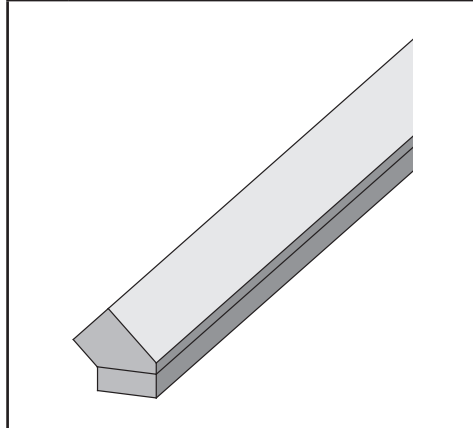

2 x K1	1874 x 76 x 38 mm	ID 43464
---------------	-------------------	----------

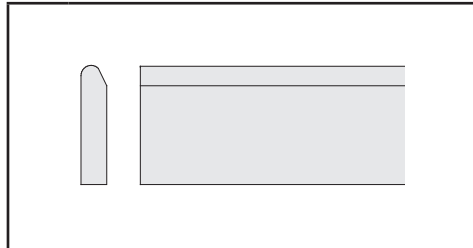

2 x G1	1884 x 45 x 17 mm	ID 48538
2 x G2	1884 x 58 x 17 mm	ID 48521
2 x G3	1980 x 95 x 17 mm	ID 48540

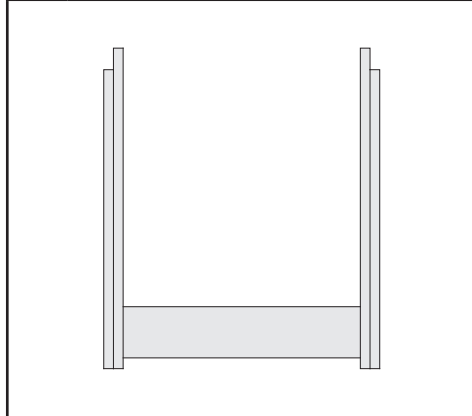

1 x L4	895 x 500 x 95 mm	ID 10033
2 x L5	595 x 550 x 95 mm	ID 62992
1 x L6	895 x 550 x 95 mm	ID 16811

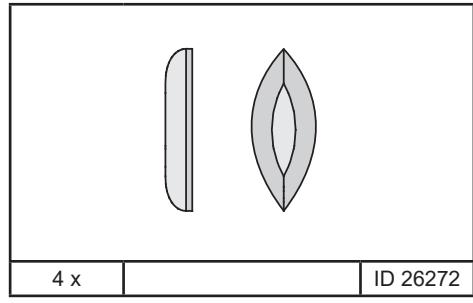

4 x		ID 26272
-----	--	----------

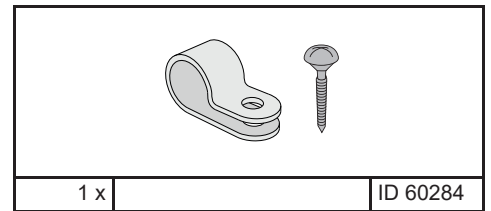
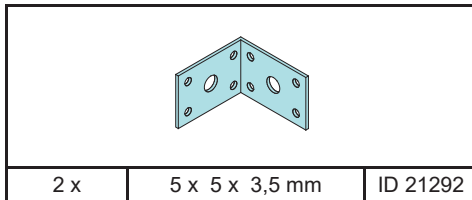
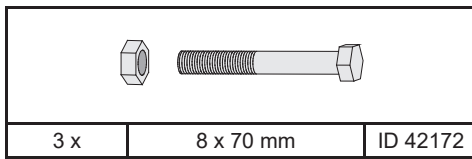
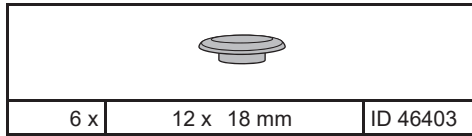
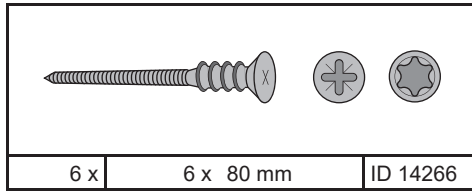
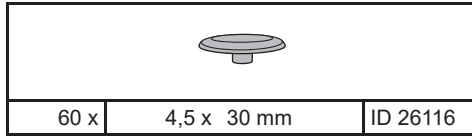
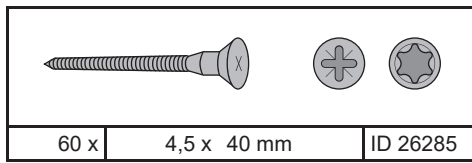
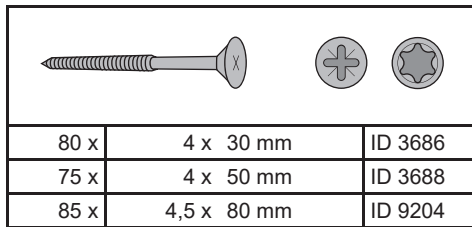
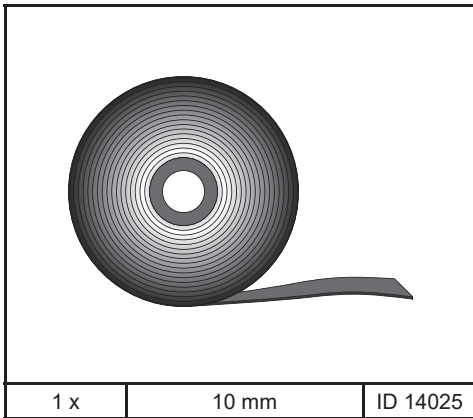
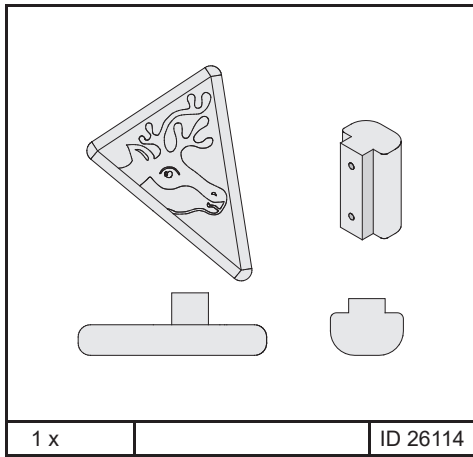
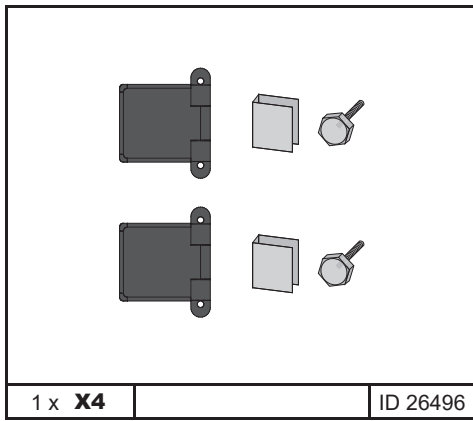

-  Übersicht
-  Overview
-  enquête

-  overzicht
-  undersøgelse
-  estudio

-  sondaggio
-  přehled
-  Pregled

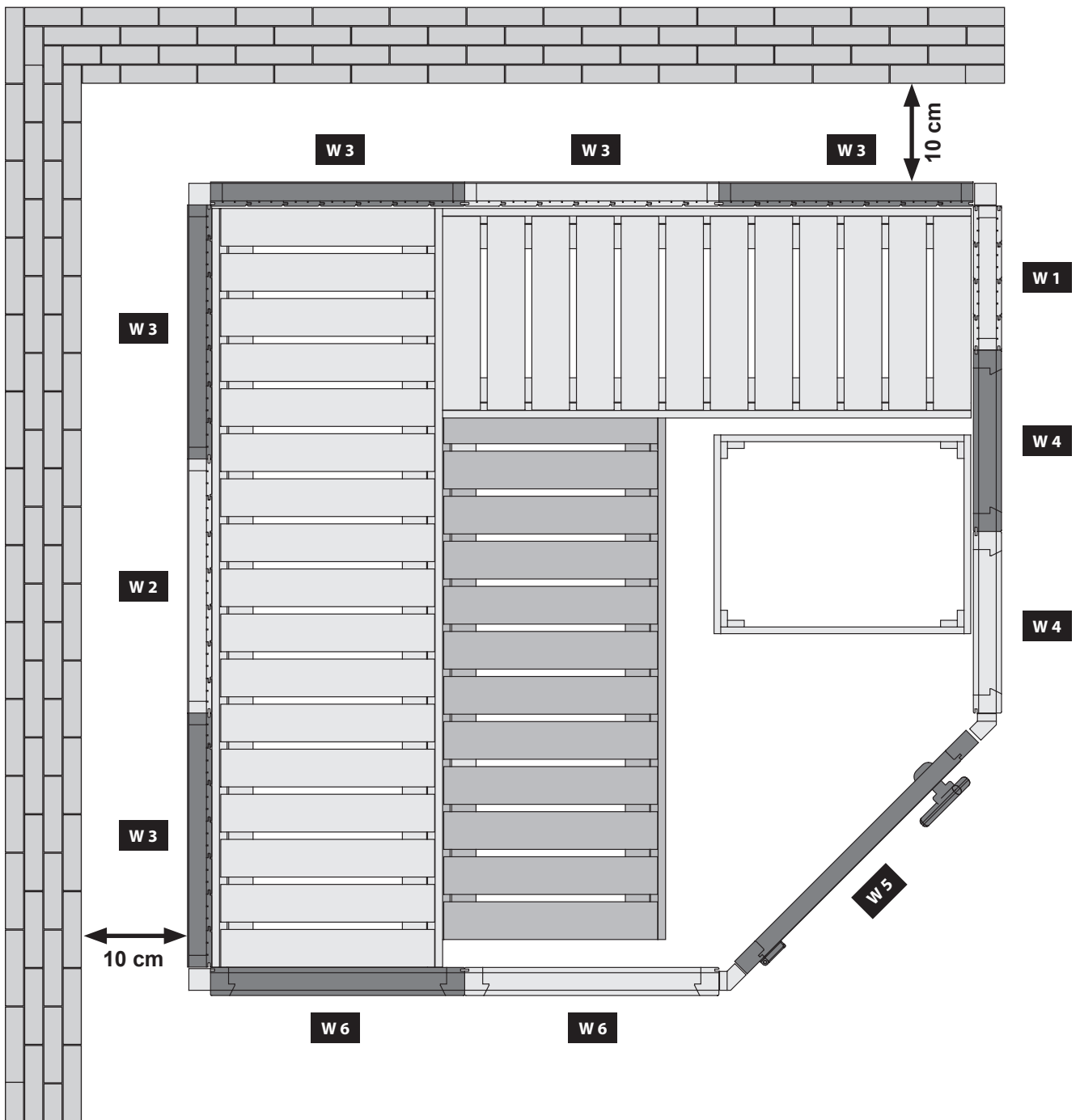
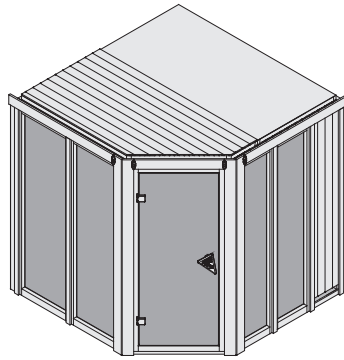

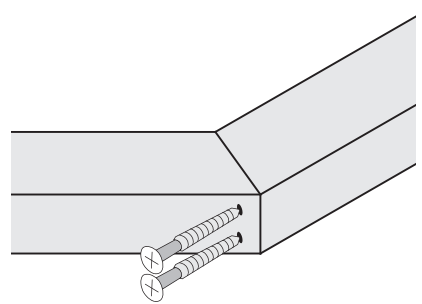
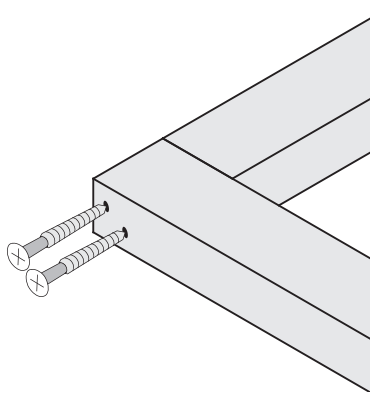
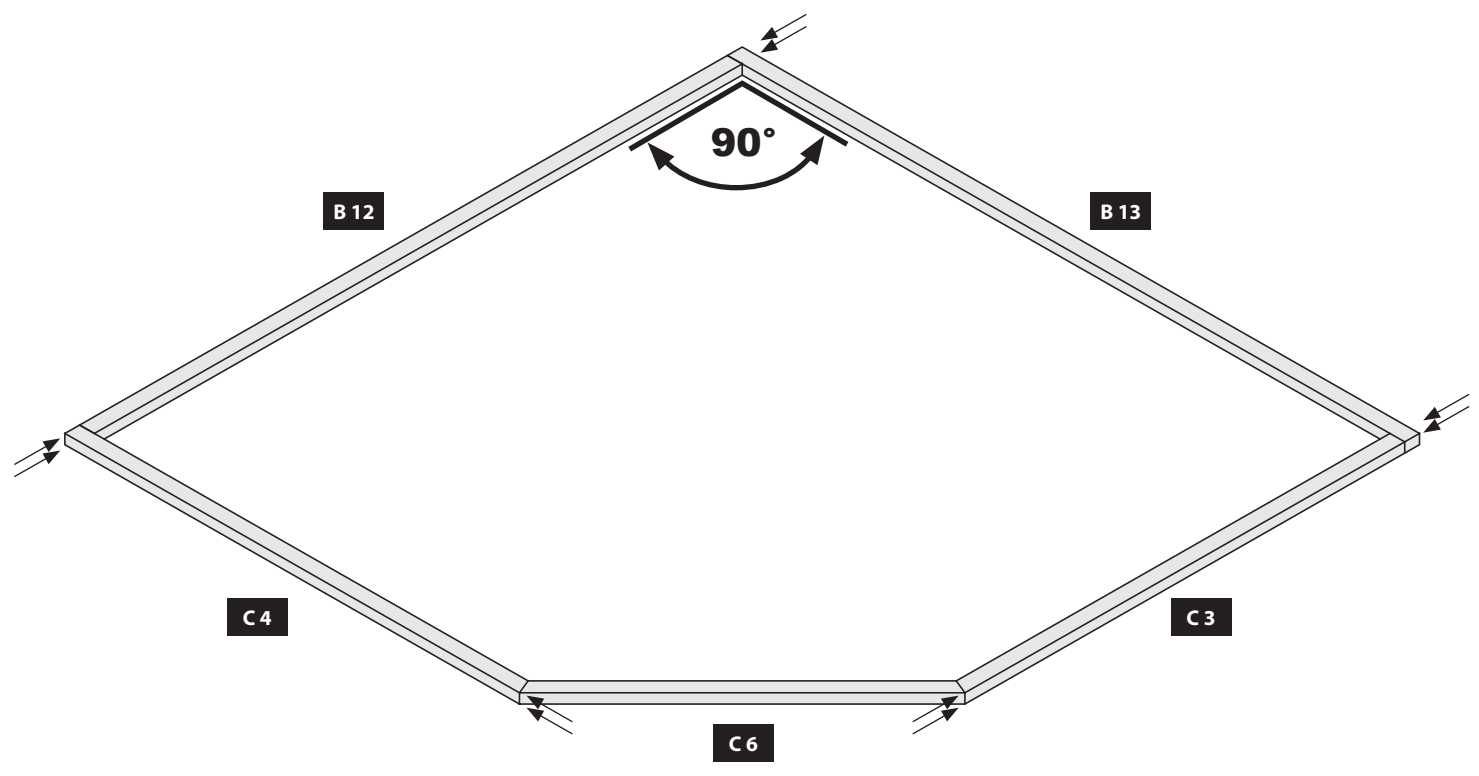
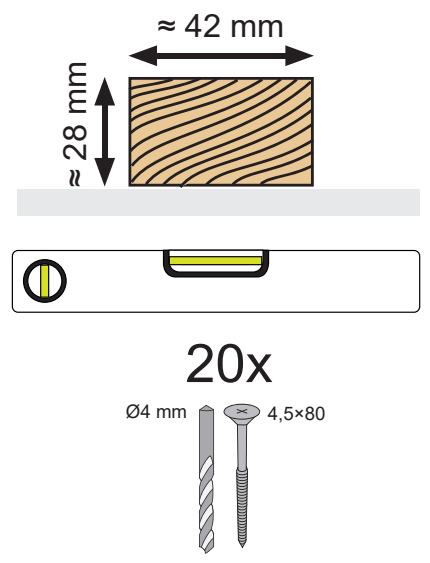
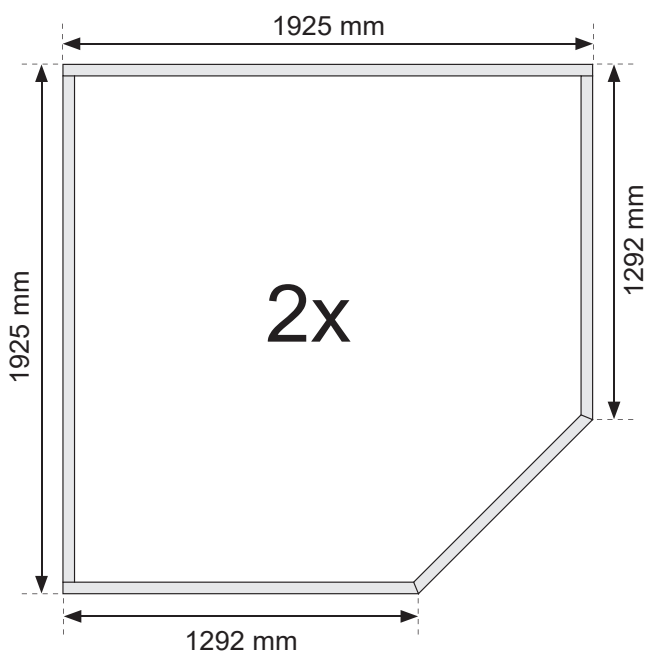

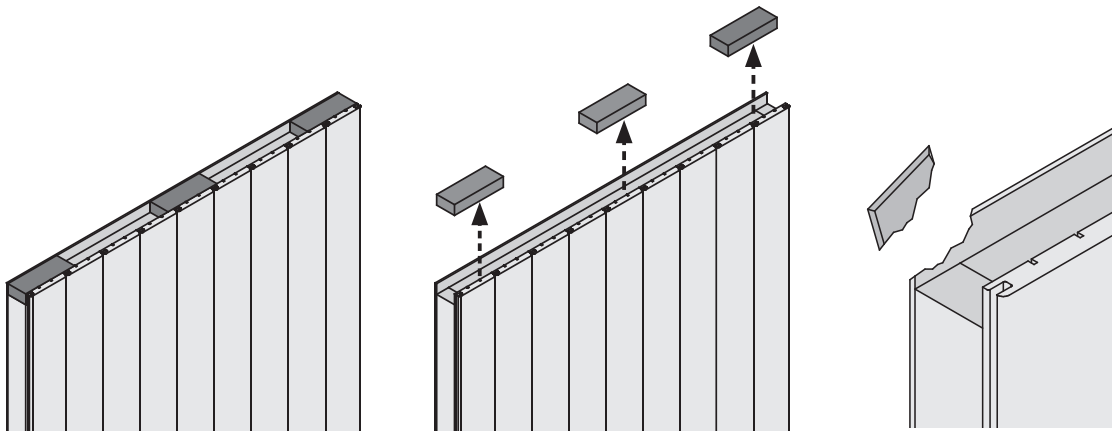

-  Vorsicht!
-  Voorzichtig!
-  Attention!
-  Attention!
-  Cuidado!
-  Occhio!
-  Pozor!
-  Opozorilo!

02

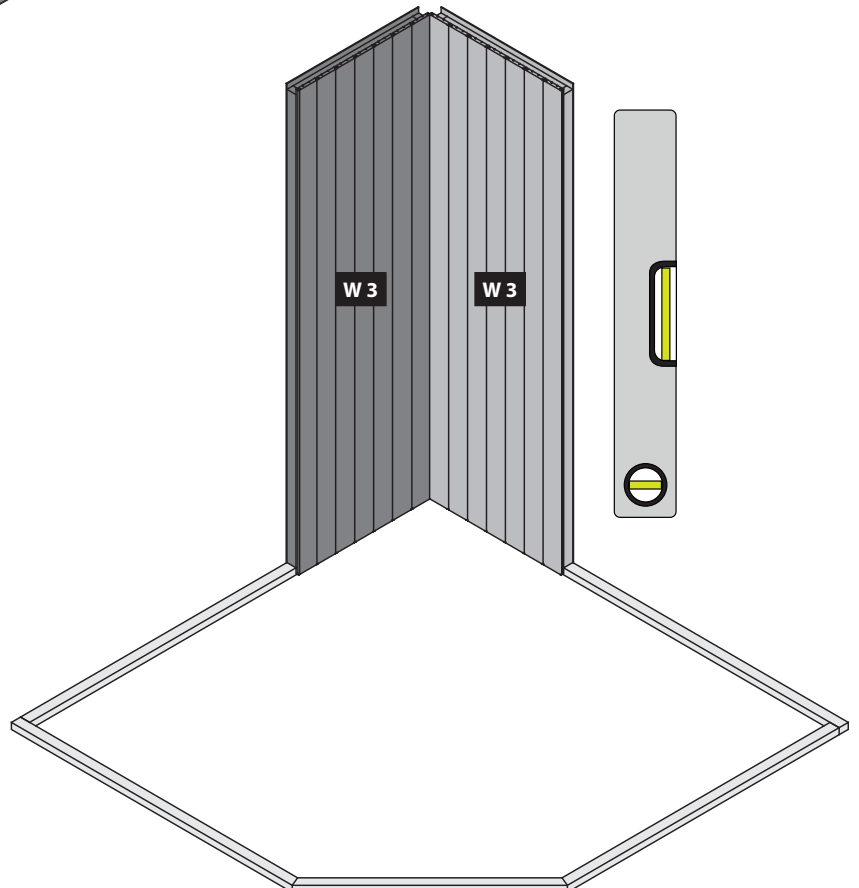
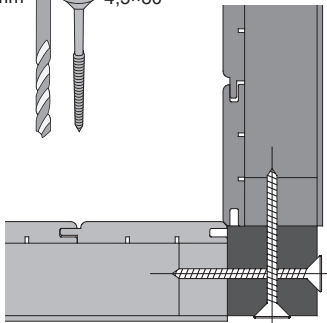
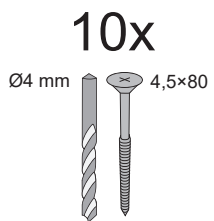
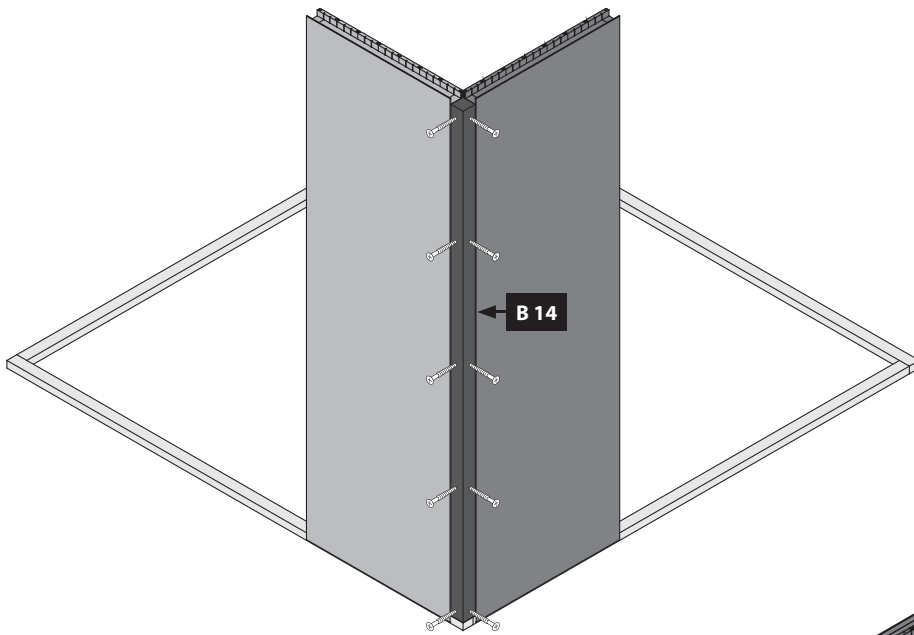

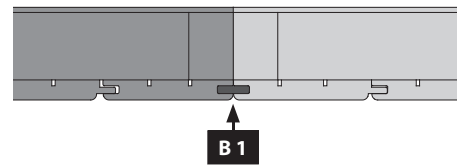
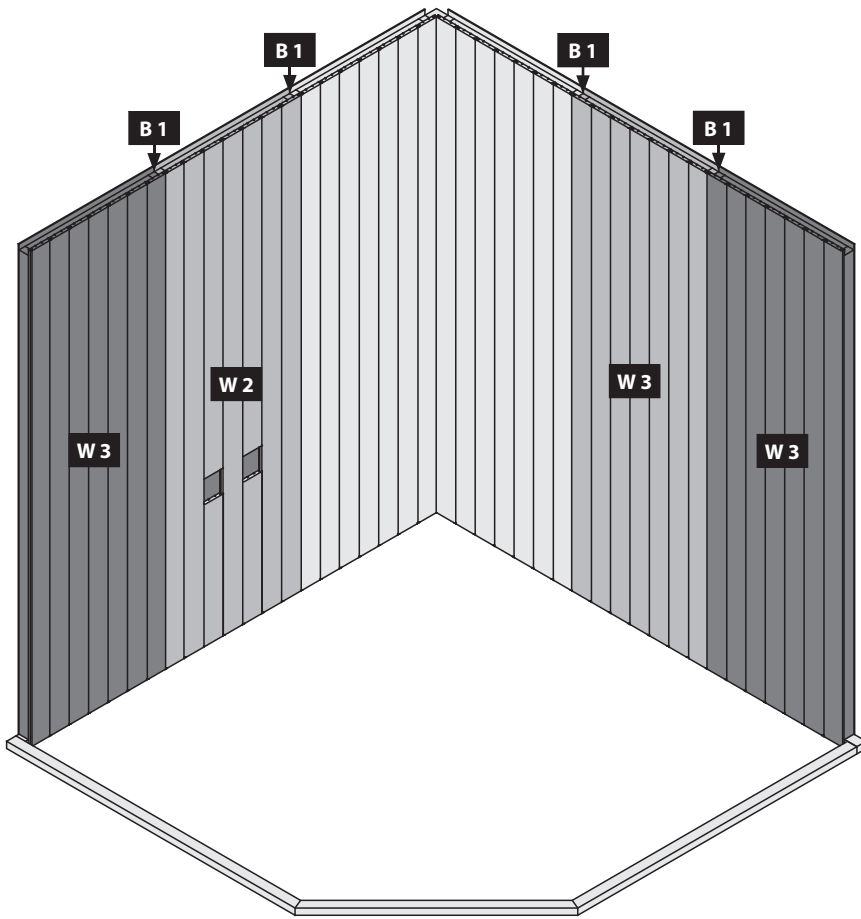

10x

Ø4 mm 4,5x80

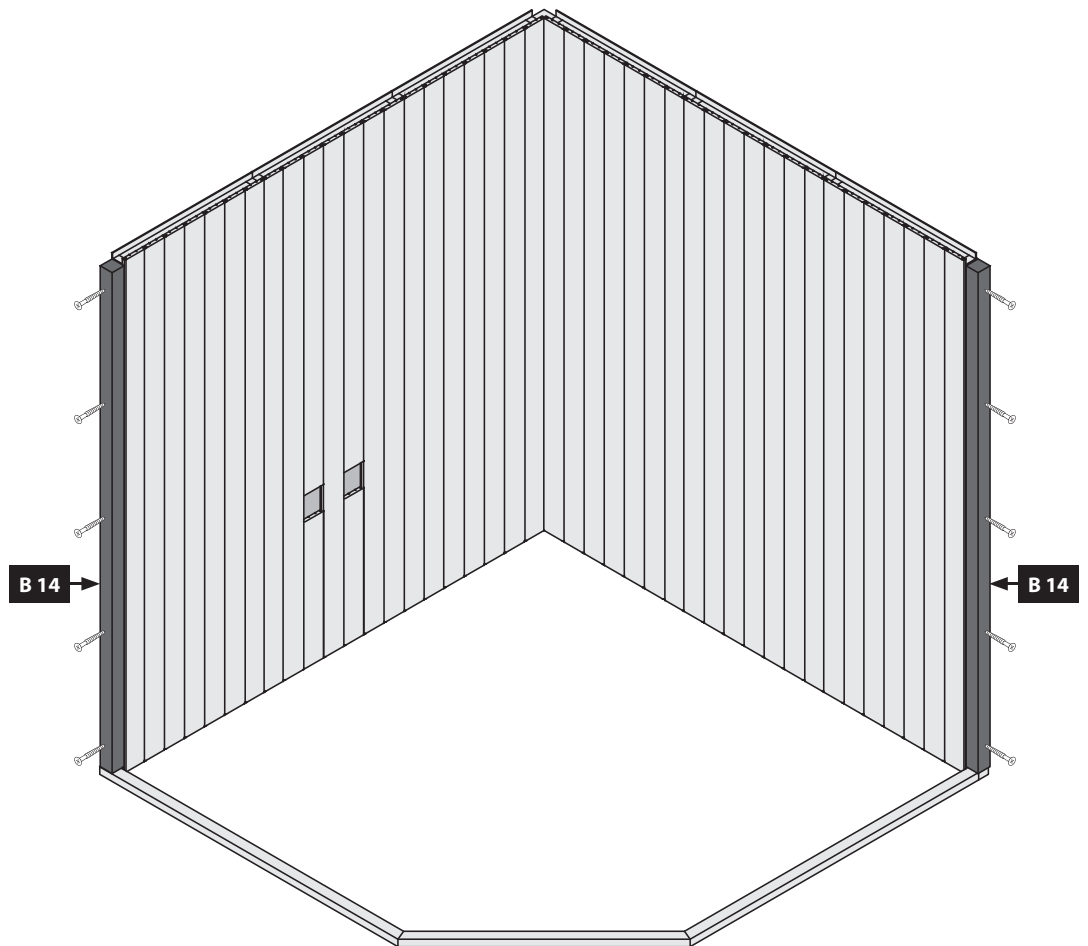
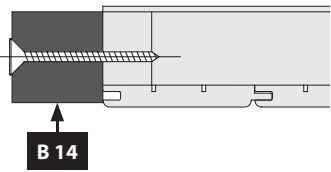
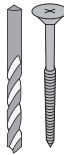

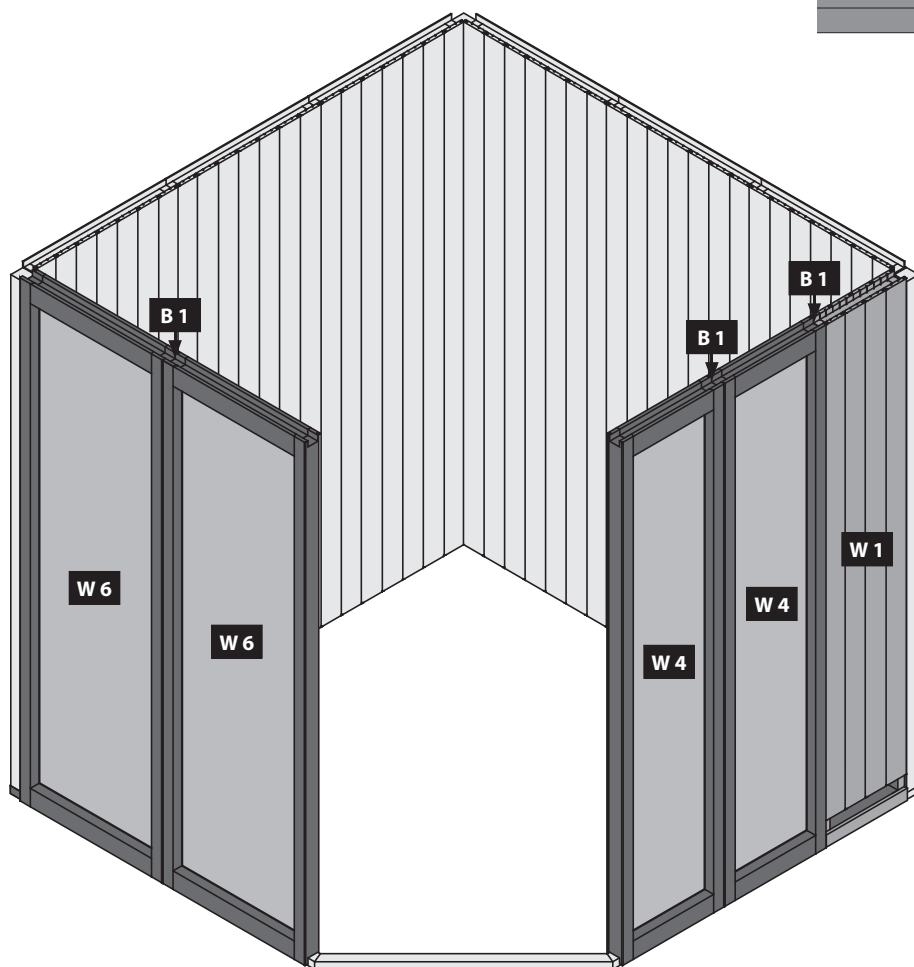
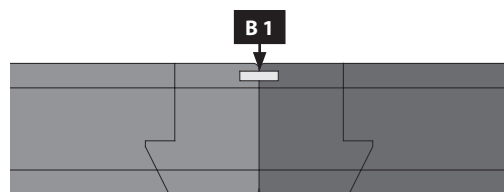
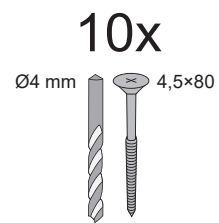
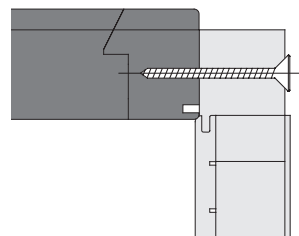
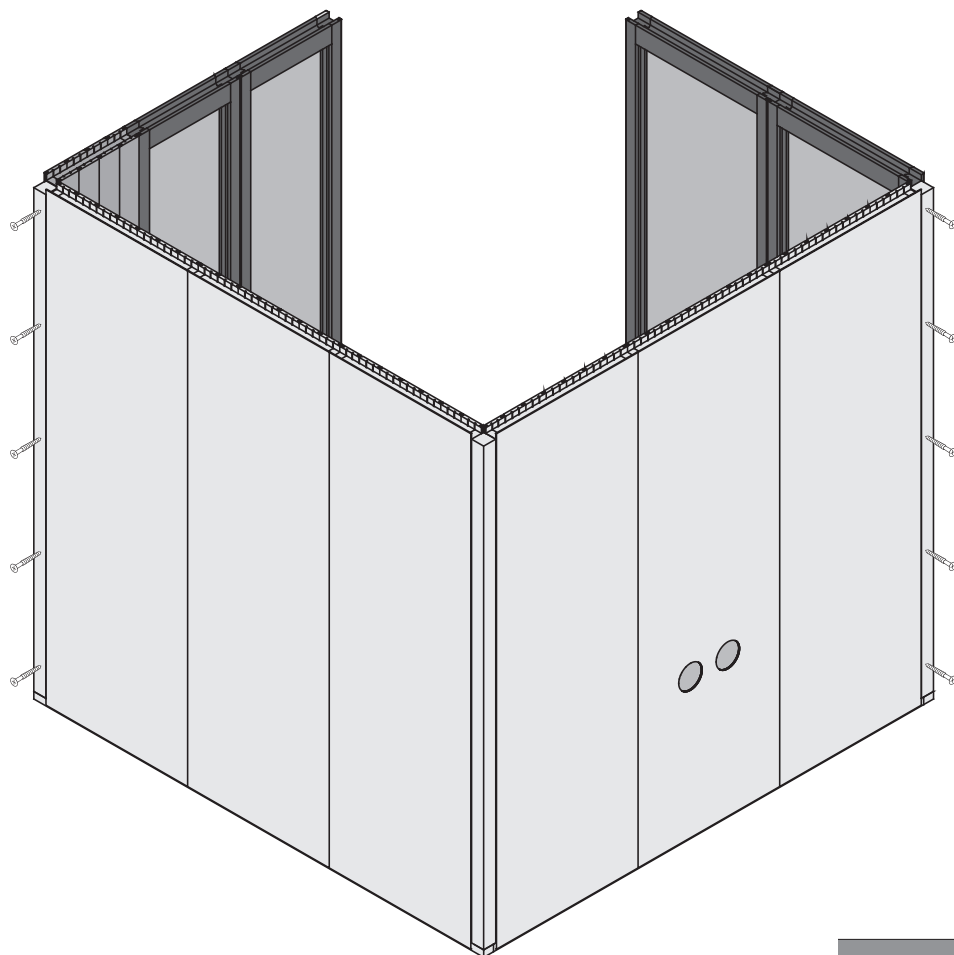

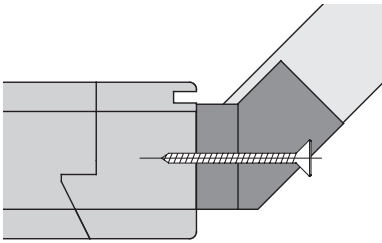

10x

Ø4 mm 4,5x80

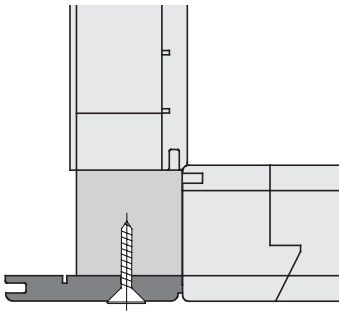
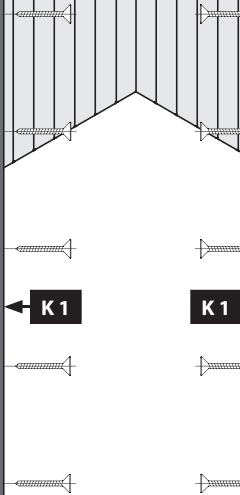
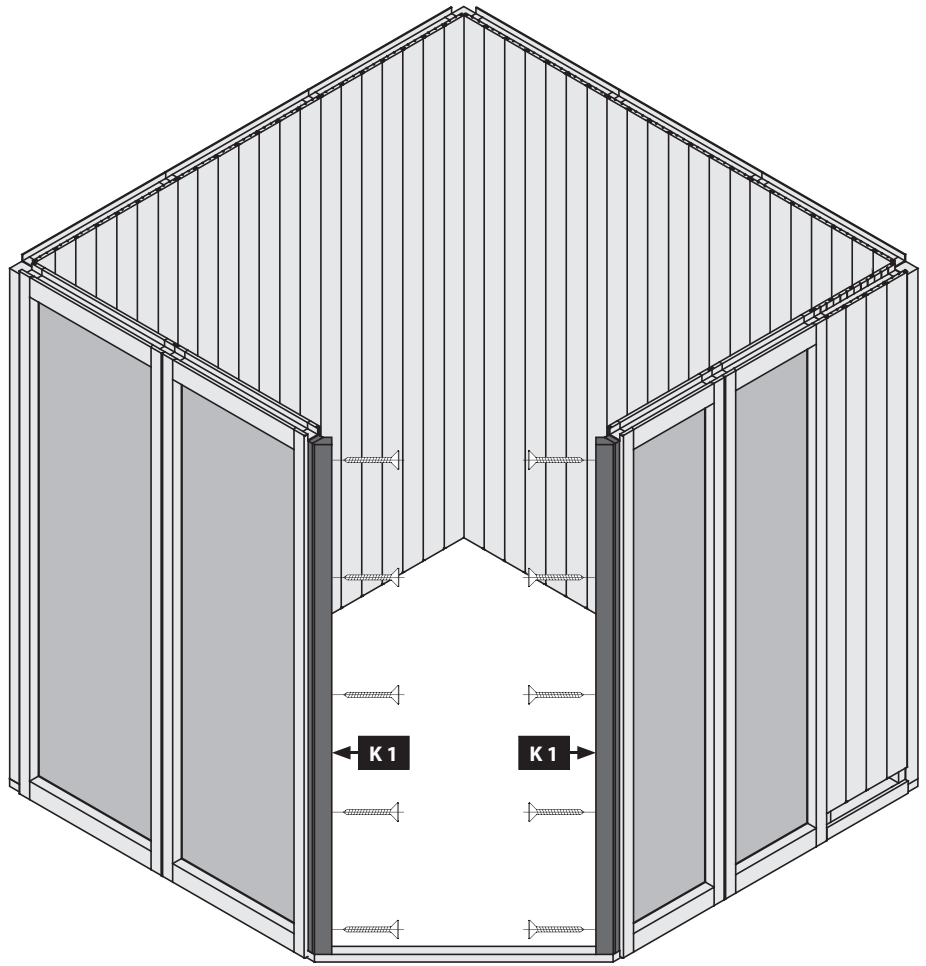
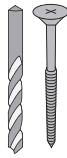

8x

Ø4 mm 4,5x40

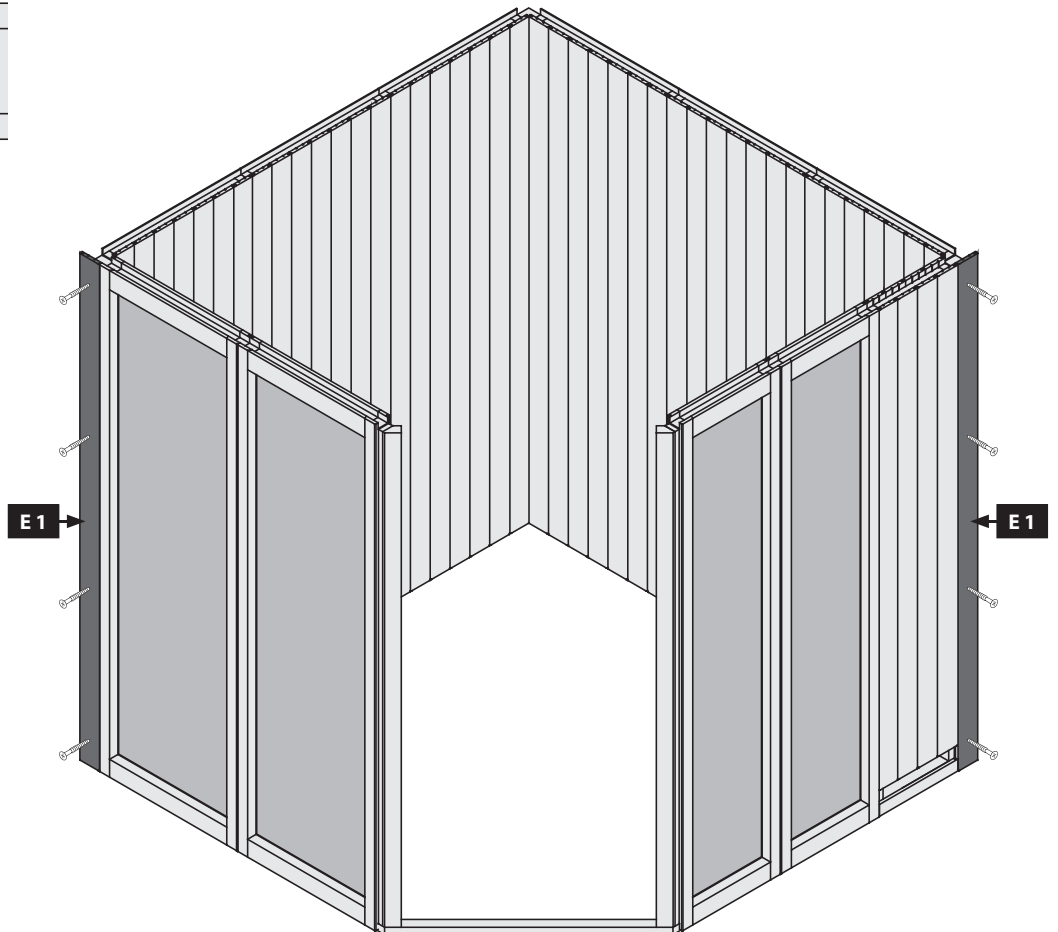
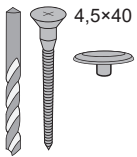

E1

E1

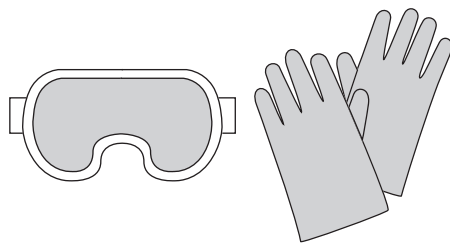

07

-  Tür in den Rahmen legen
-  Put the door in the frame
-  Mettez la porte dans le cadre
-  Plaats de deur in het frame
-  Sæt døren i rammen
-  Pon la puerta en el marco
-  Metti la porta nel telaio
-  Vložte dveře do rámu
-  Vrata nameštite v okvir

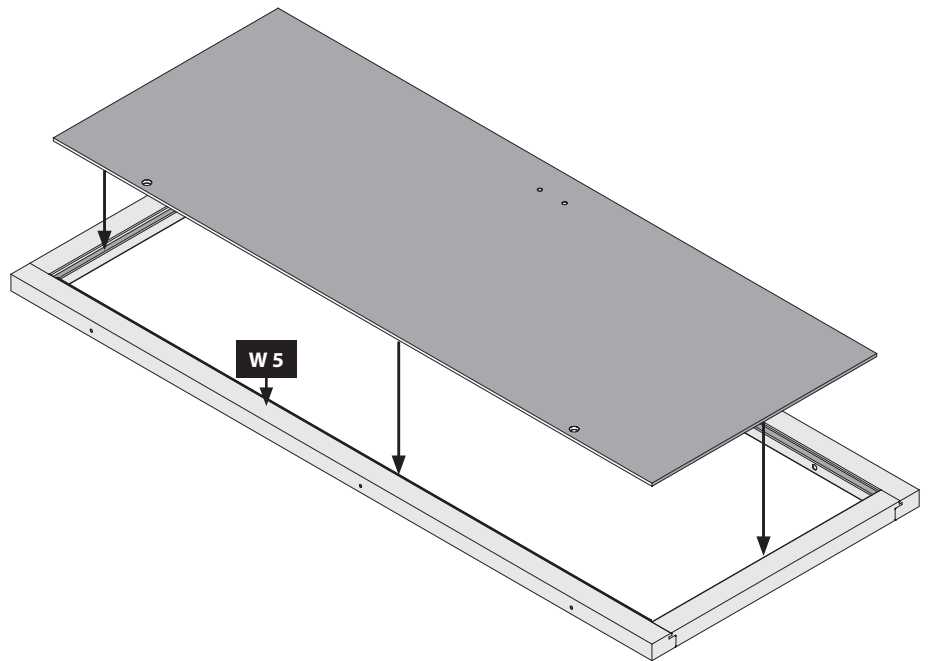

-  Tür im Rahmen ausrichten
-  Center the door in the frame
-  Aligner la porte dans le cadre
-  Lijn de deur in het frame uit
-  Juster døren i rammen
-  Alinea la puerta en el marco
-  Allinea la porta nella cornice
-  Zarovnejte dveře do rámu
-  Poravňajte vrata v okvir

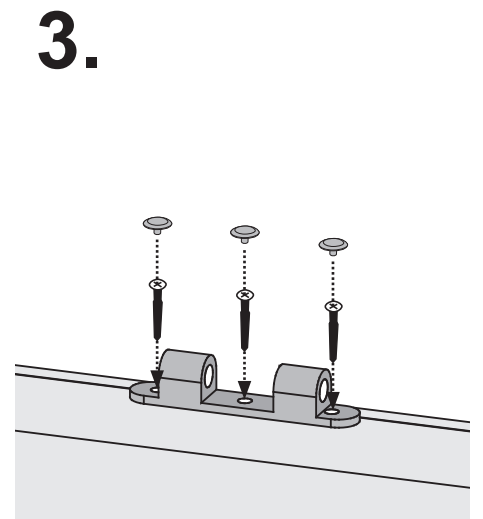
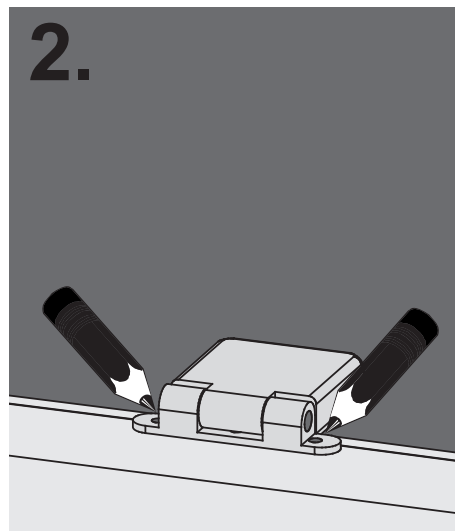
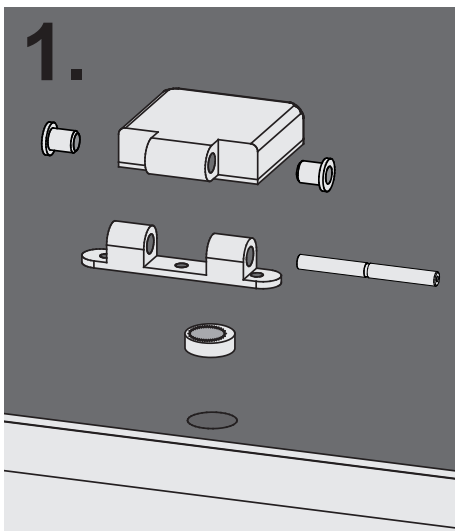
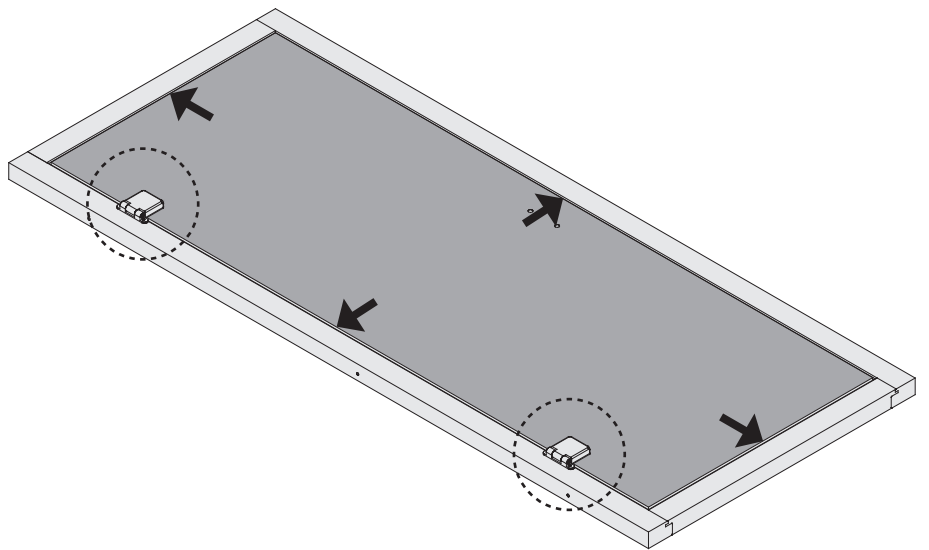

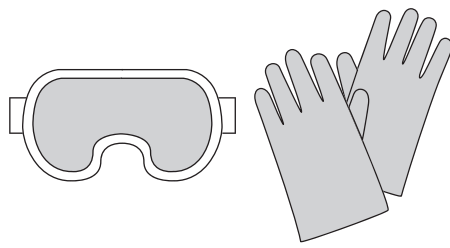

08

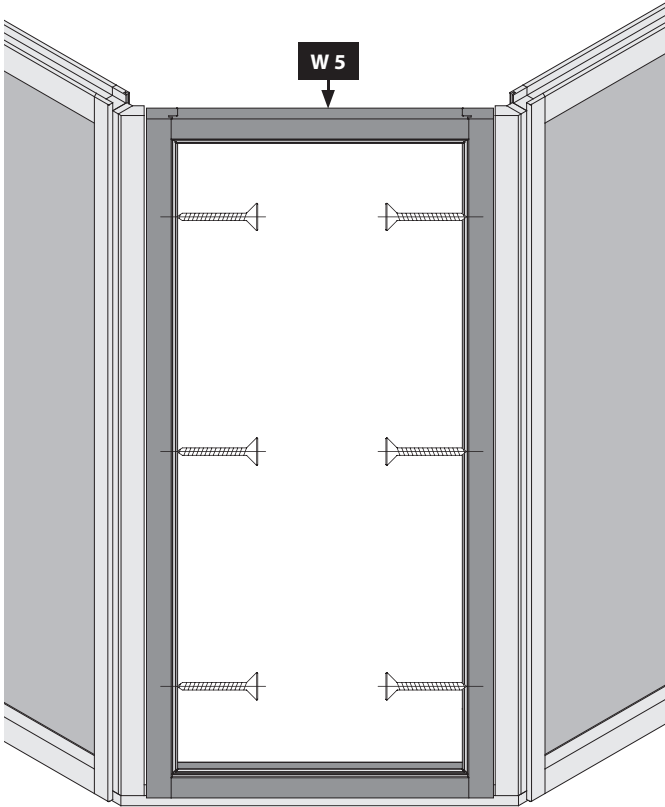

6x

6x80

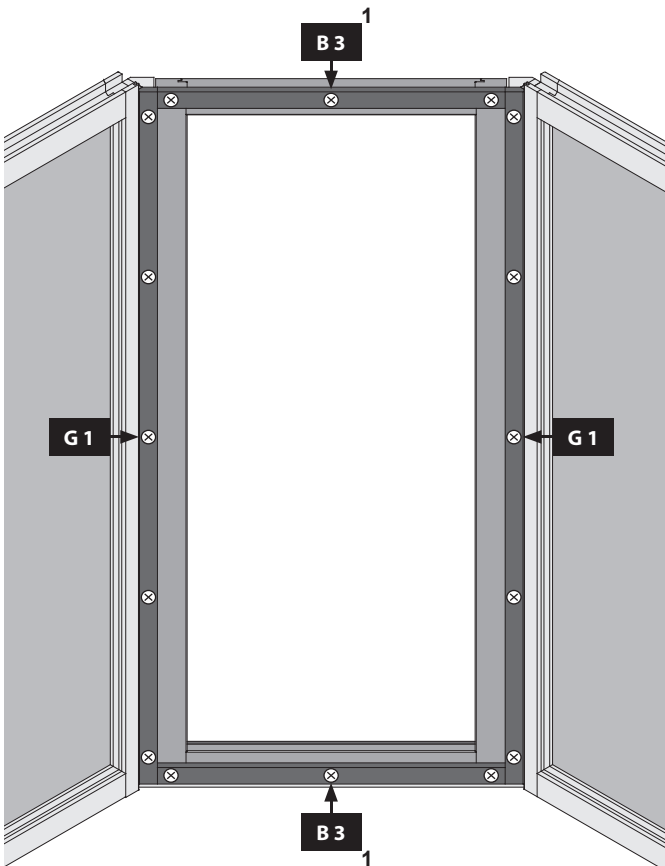
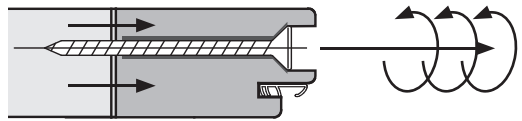
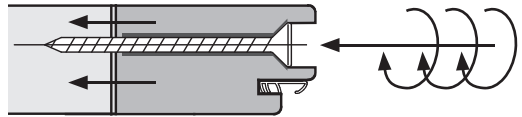
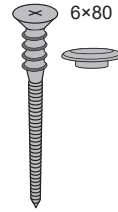

16x

Ø3 mm

4x50

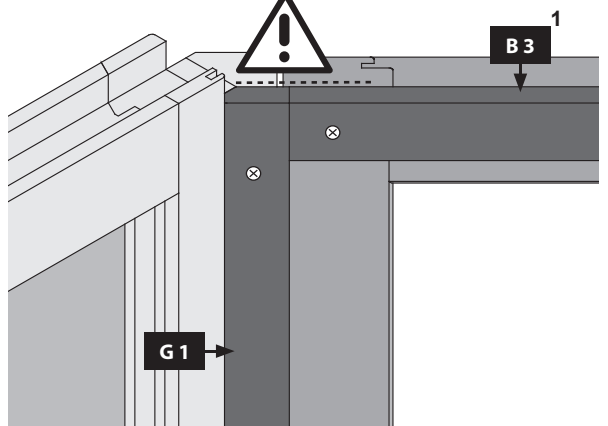
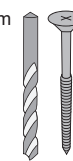

 Kabeldurchführung

 implementatie voor de kabel

 implementazione per il cavo

 implementation for the cable

 Kabelforskruning

 provedení kabelu

 mise en œuvre pour le câble

 implementación para el cable

 Kabelsko žrelo

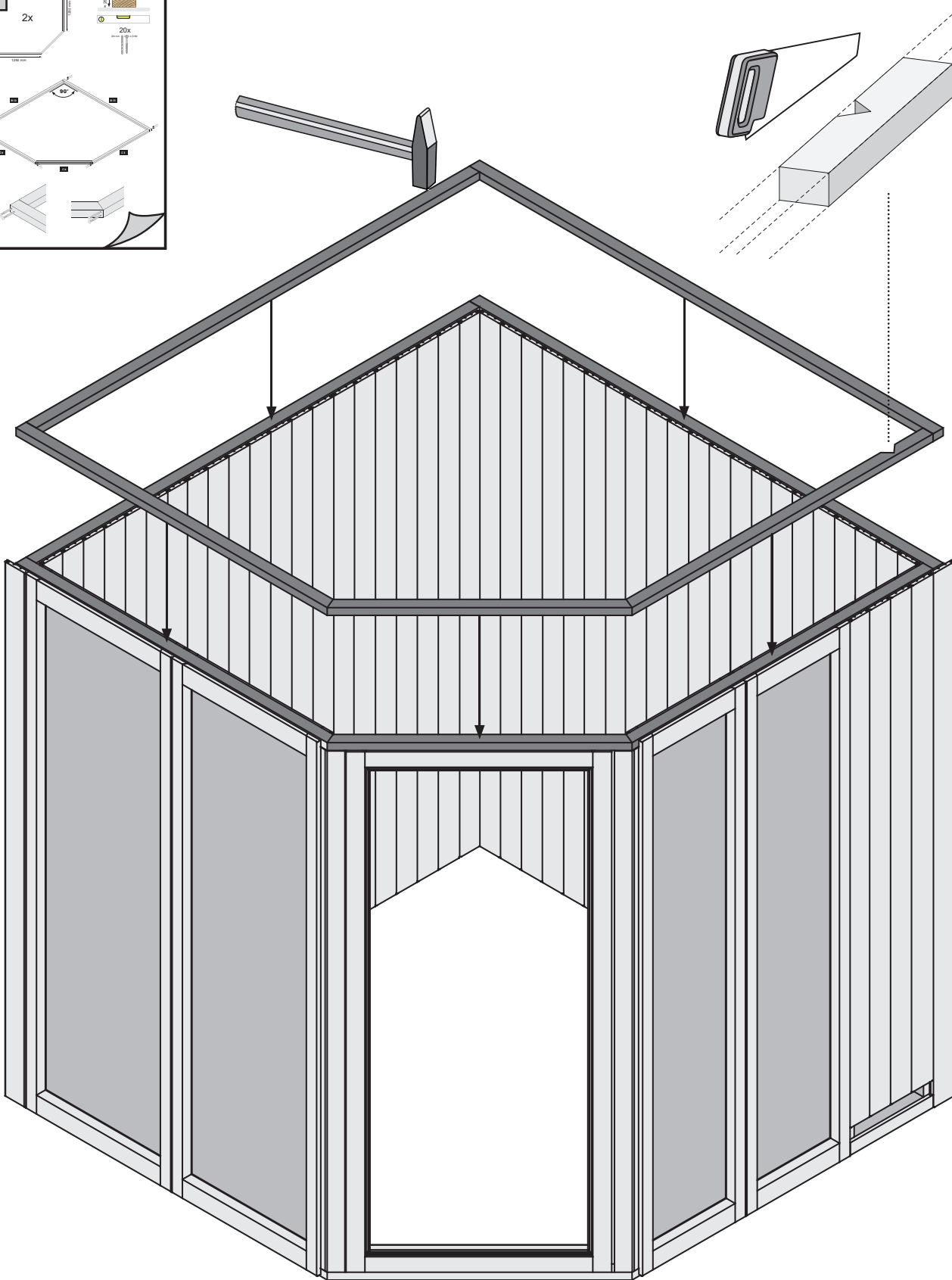
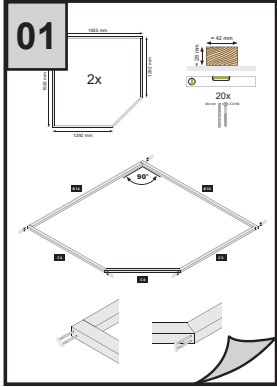

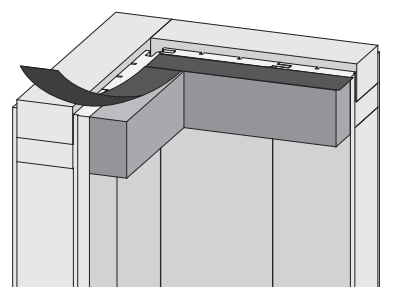
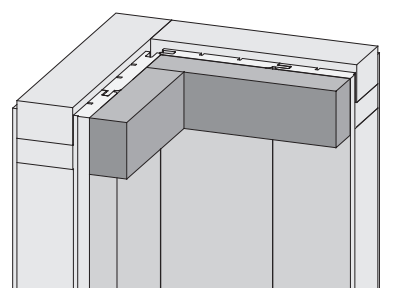
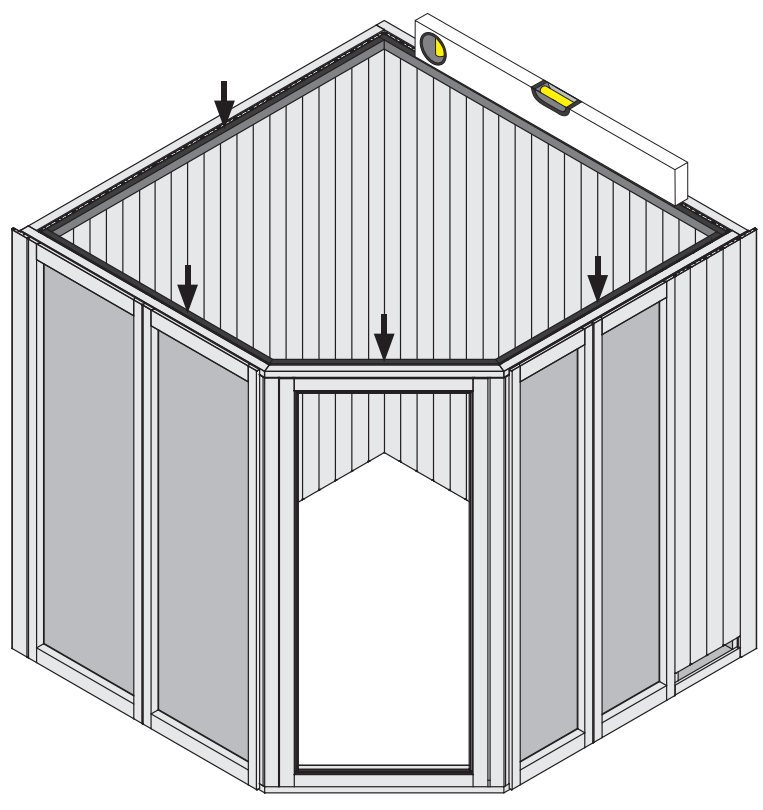
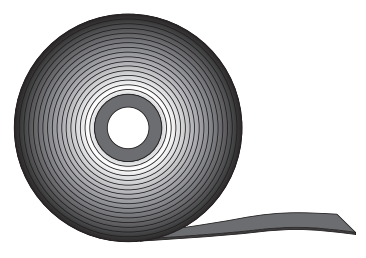
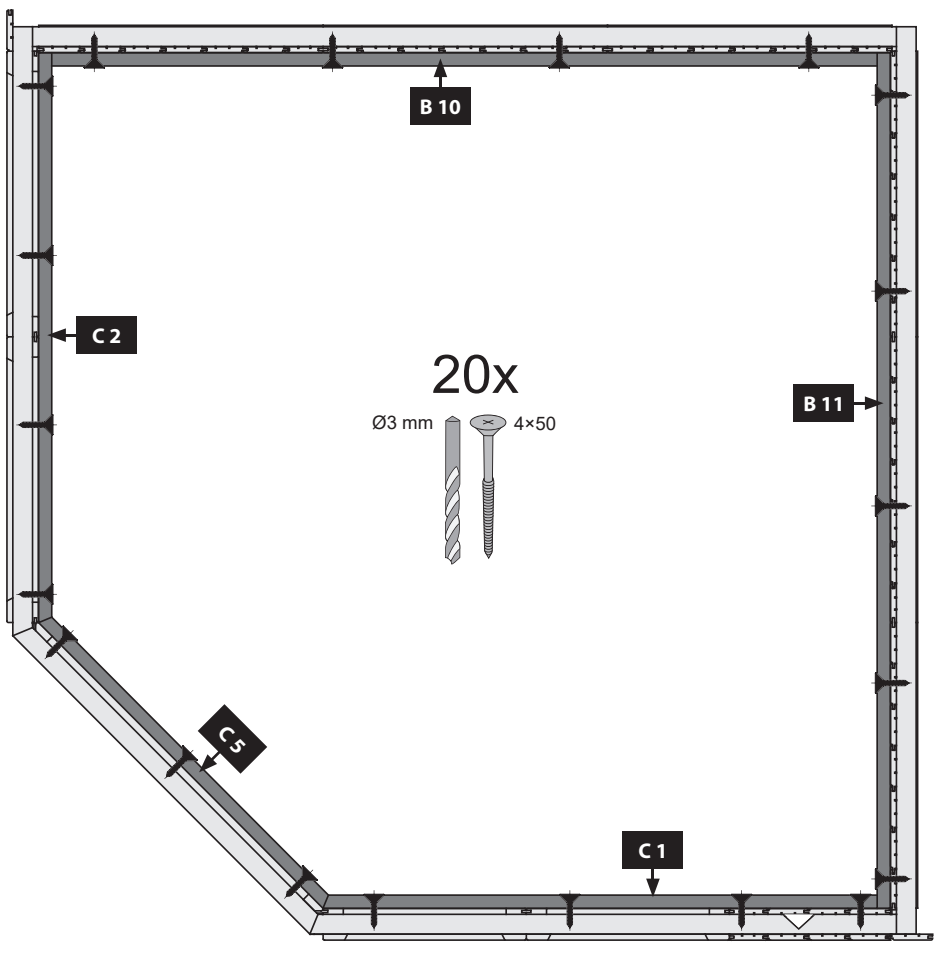
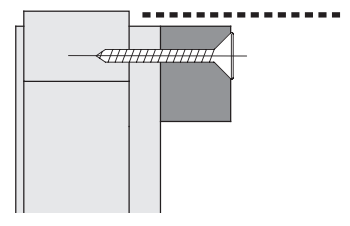

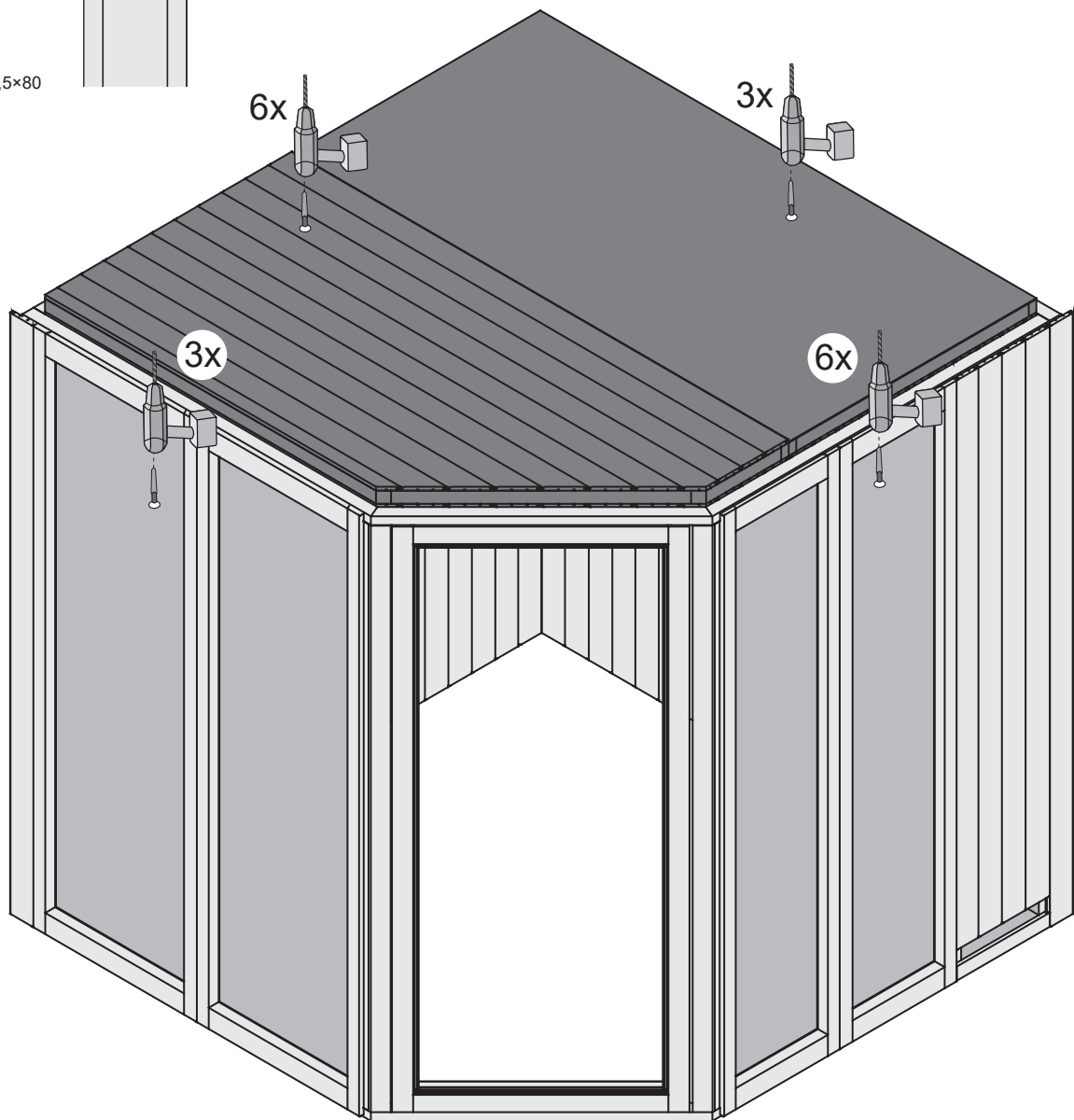
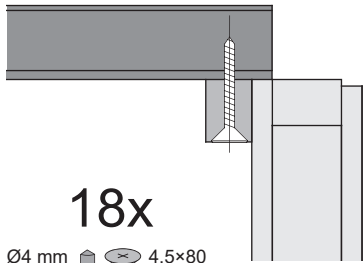
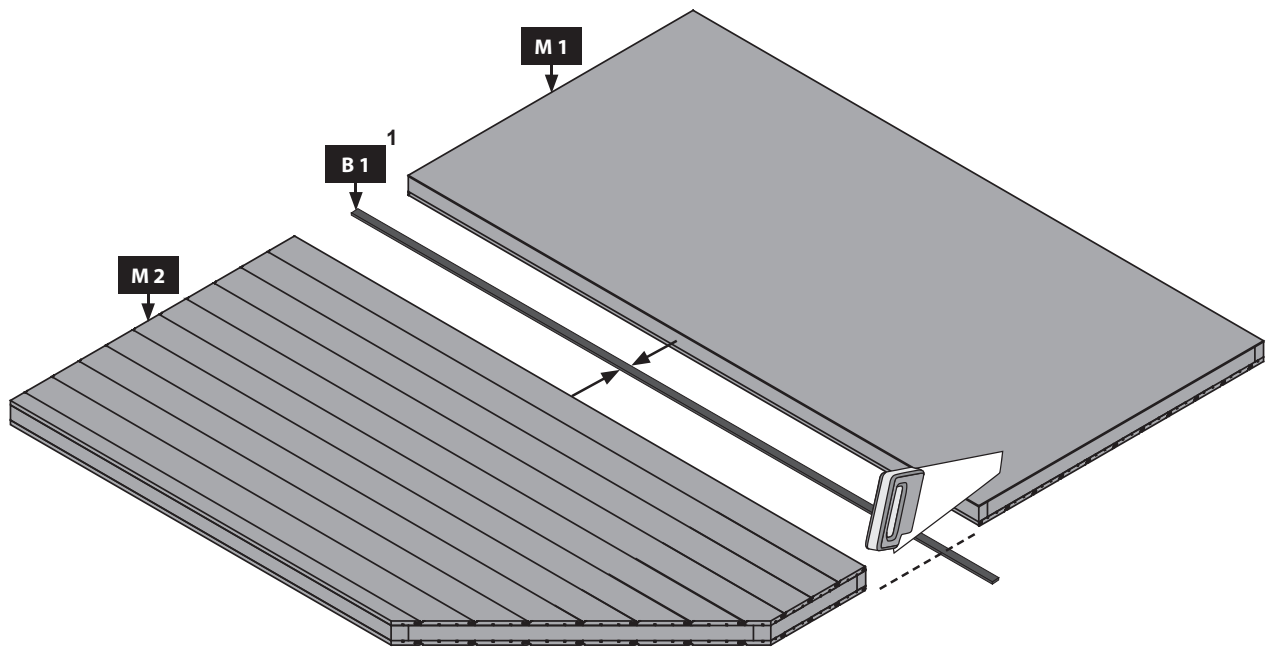

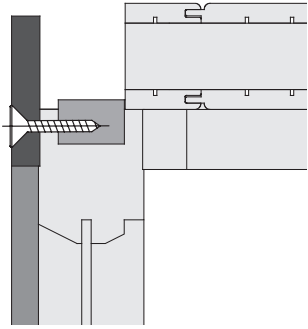

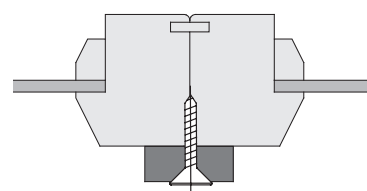
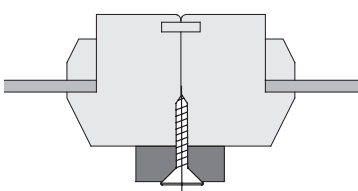
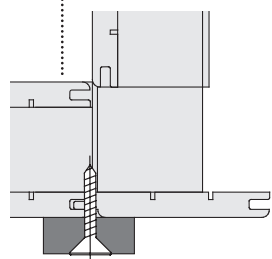
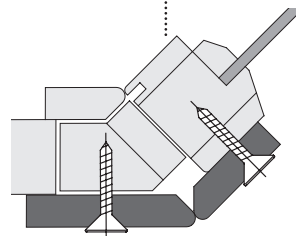
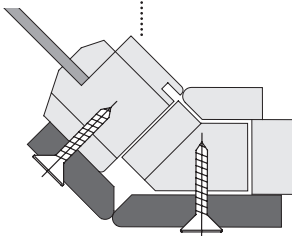
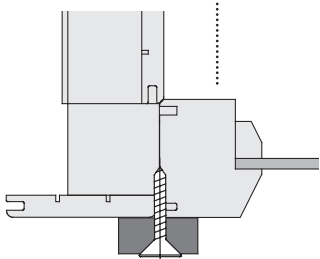
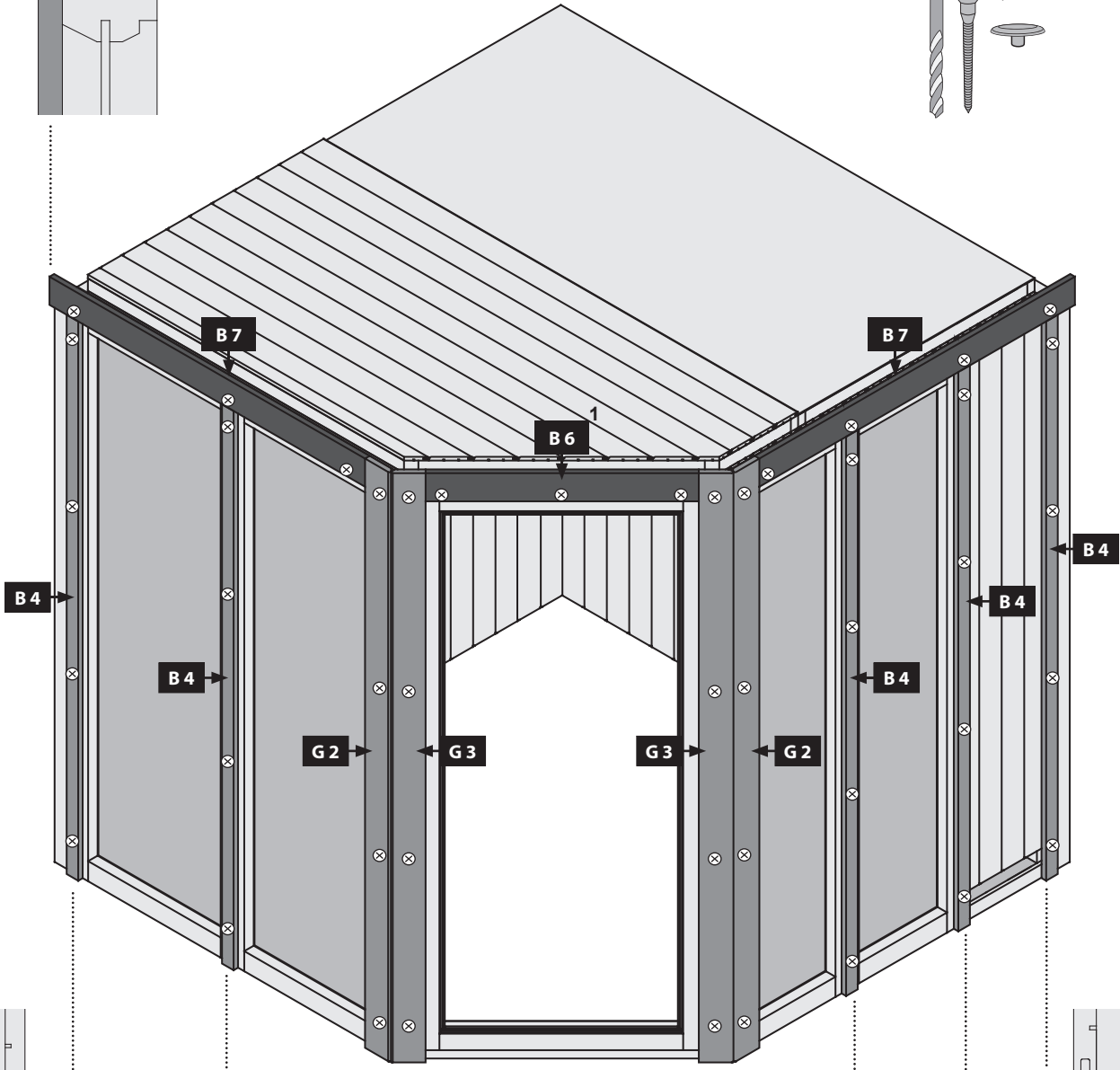
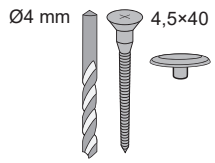

46x



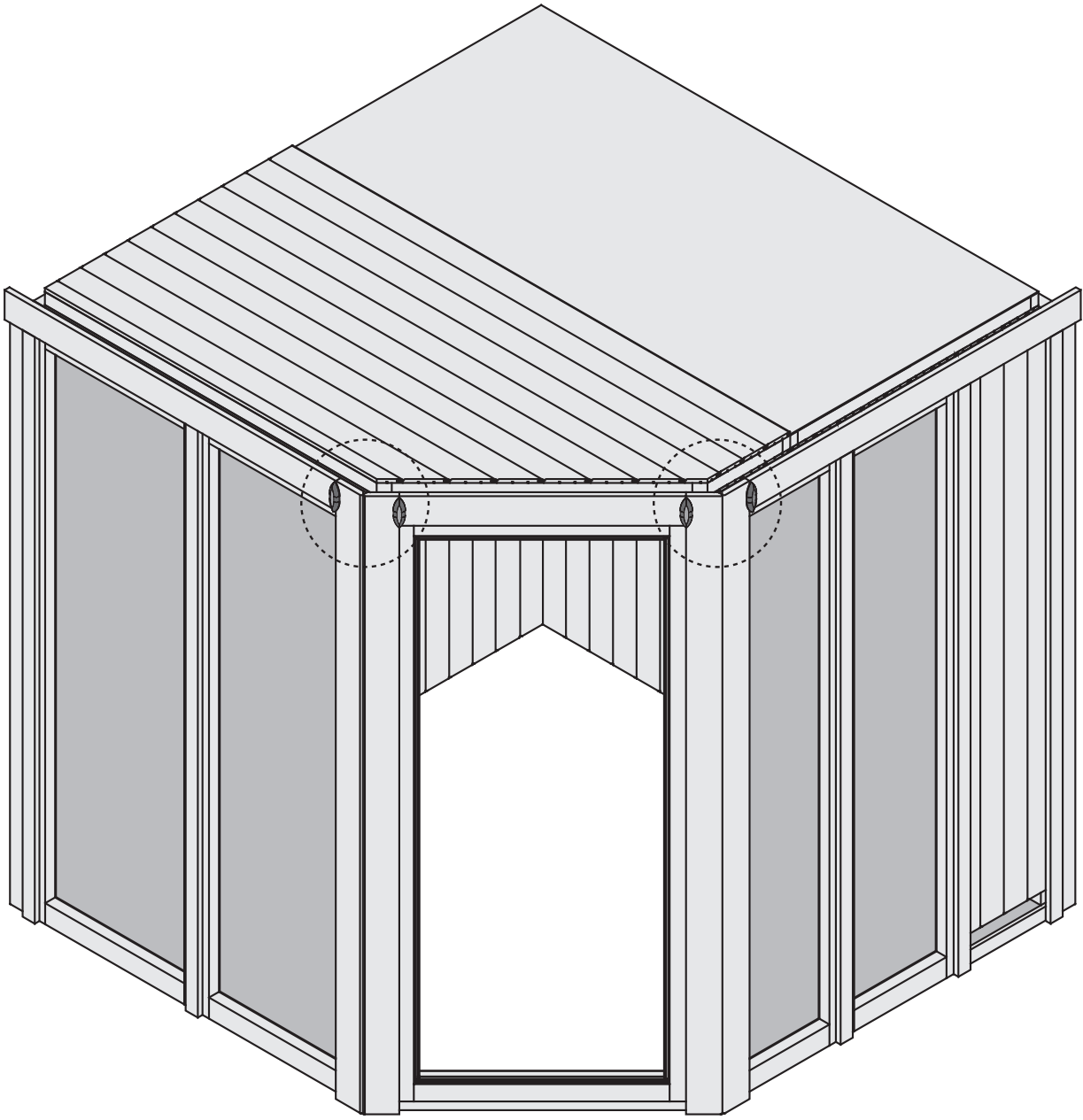
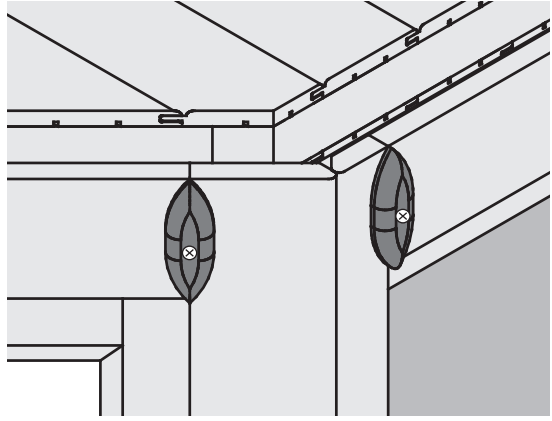
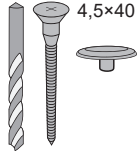

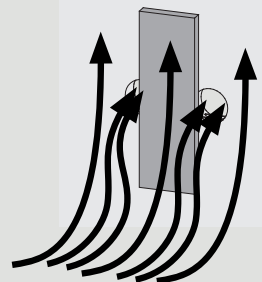
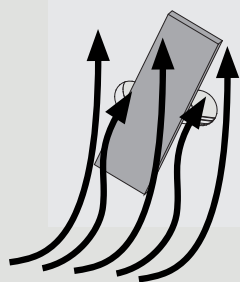
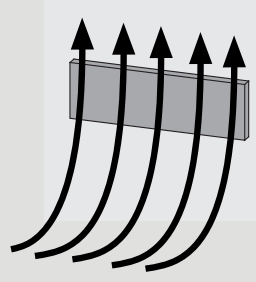
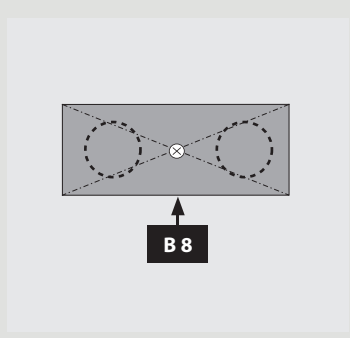
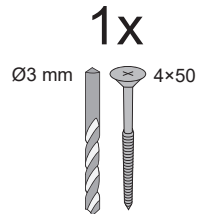
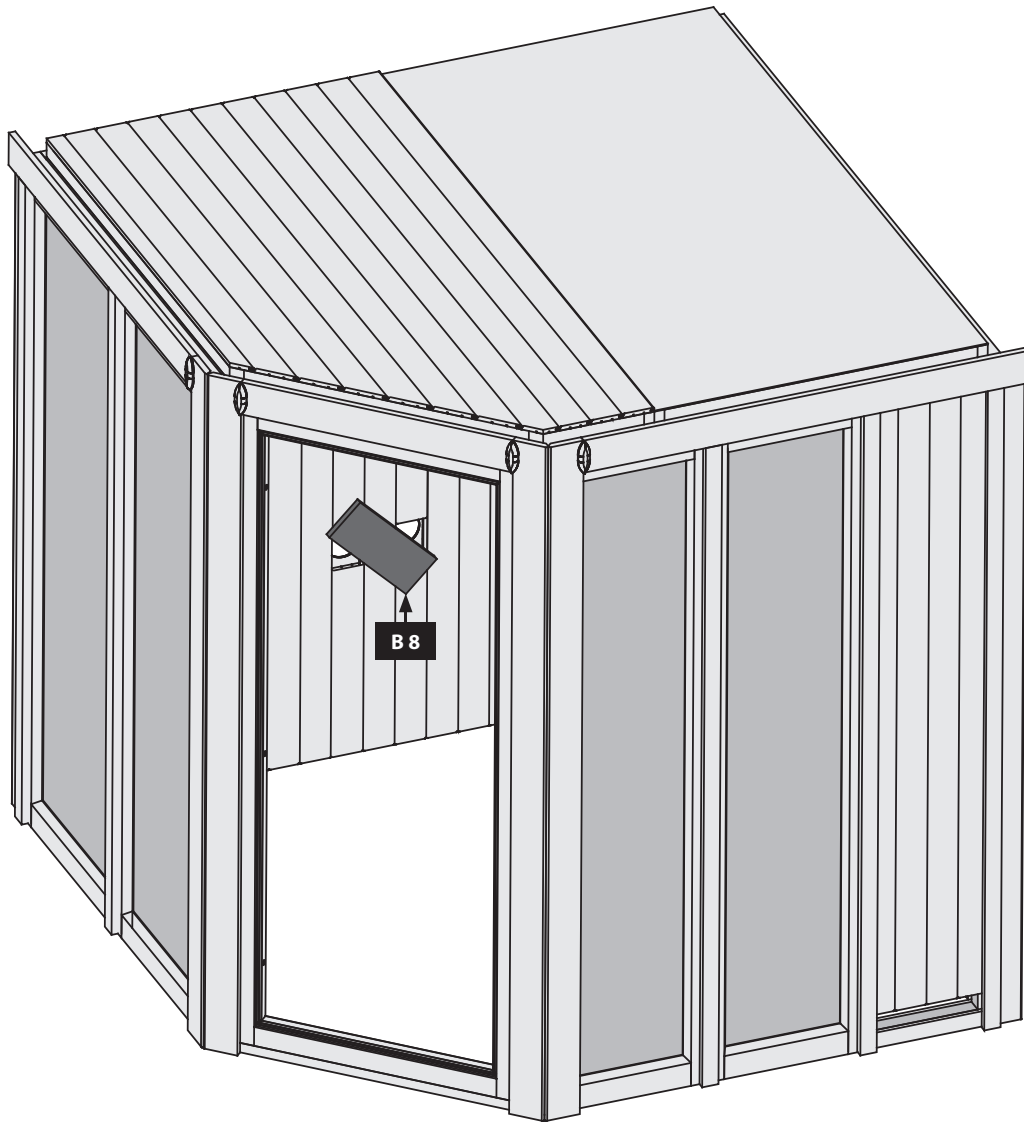
4x
Ø4 mm 4,5x40







 Hier ist die Funktionsweise des Brettes abgebildet. Regeln Sie damit die Abluft nach Ihren eigenen Wünschen

 This figure shows the functional principle of the board. Regulate the exhaust air according to your own wishes

 Ceci représente le mode de fonctionnement de la planche. Avec elle, réglez l'écoulement de l'air selon vos désirs.

 Hier is de werking van het plankje afgebeeld. Regel daarmee de luchtafvoer naar eigen wens

 Sådan fungerer styret. Brug den til at regulere udstødningsluften efter dine egne ønsker

 Aquí está representada la forma de funcionamiento de la tabla. Regule con ello el aire de salida según sus propios deseos

 Viene illustrato il principio di funzionamento della tavoletta di regolazione della ventilazione. Con essa si può regolare a piacere la ventilazione

 Zde je zobrazená funkce desky. Regulujte s ní odsávací vzduch dle Vašeho přání

 Tukaj si lahko ogledate delovanje plošče. Z njo lahko uravnavate izpušni zrak po lastnih željah.

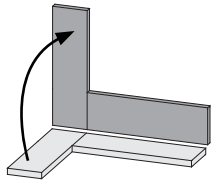

1.

2.

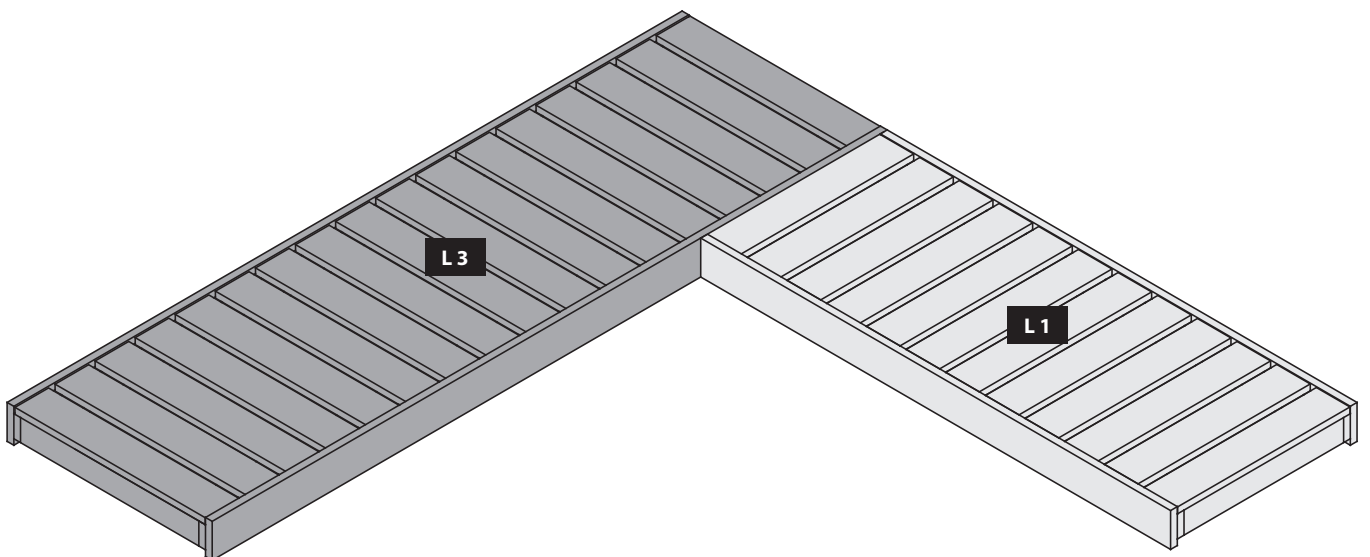
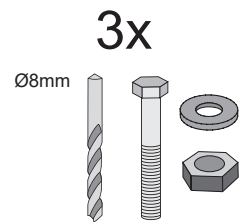
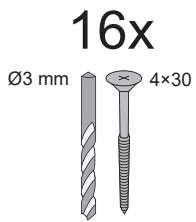
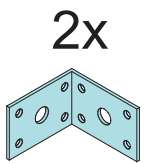
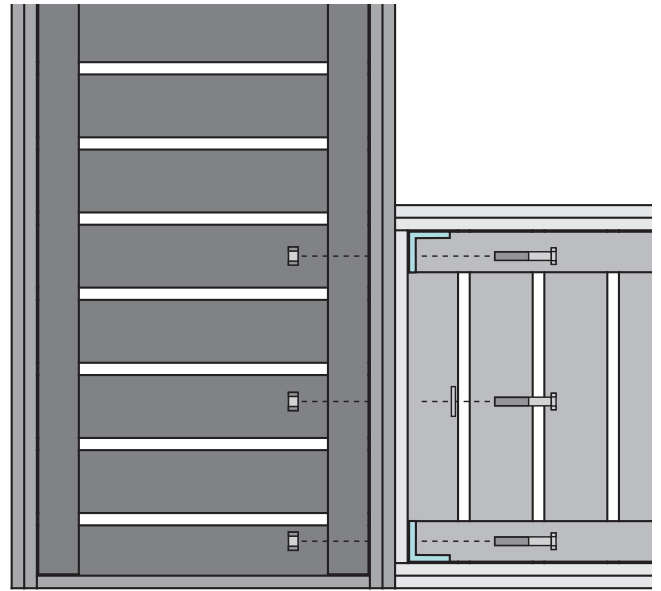
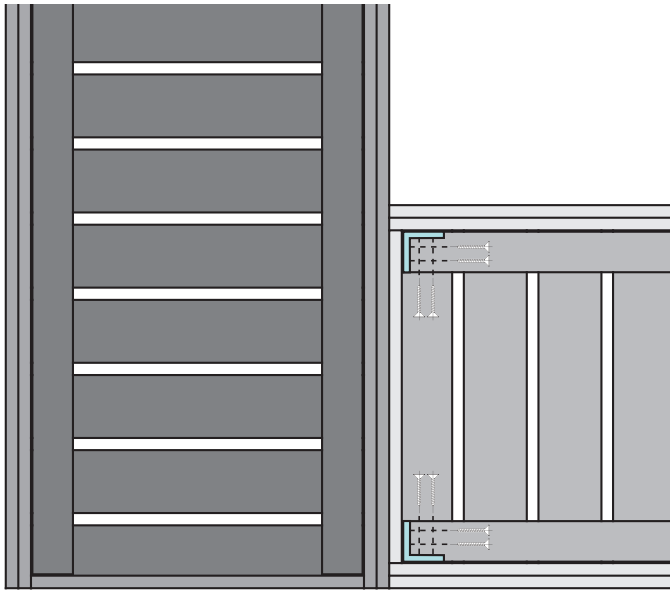



12x

Ø3 mm 4x50

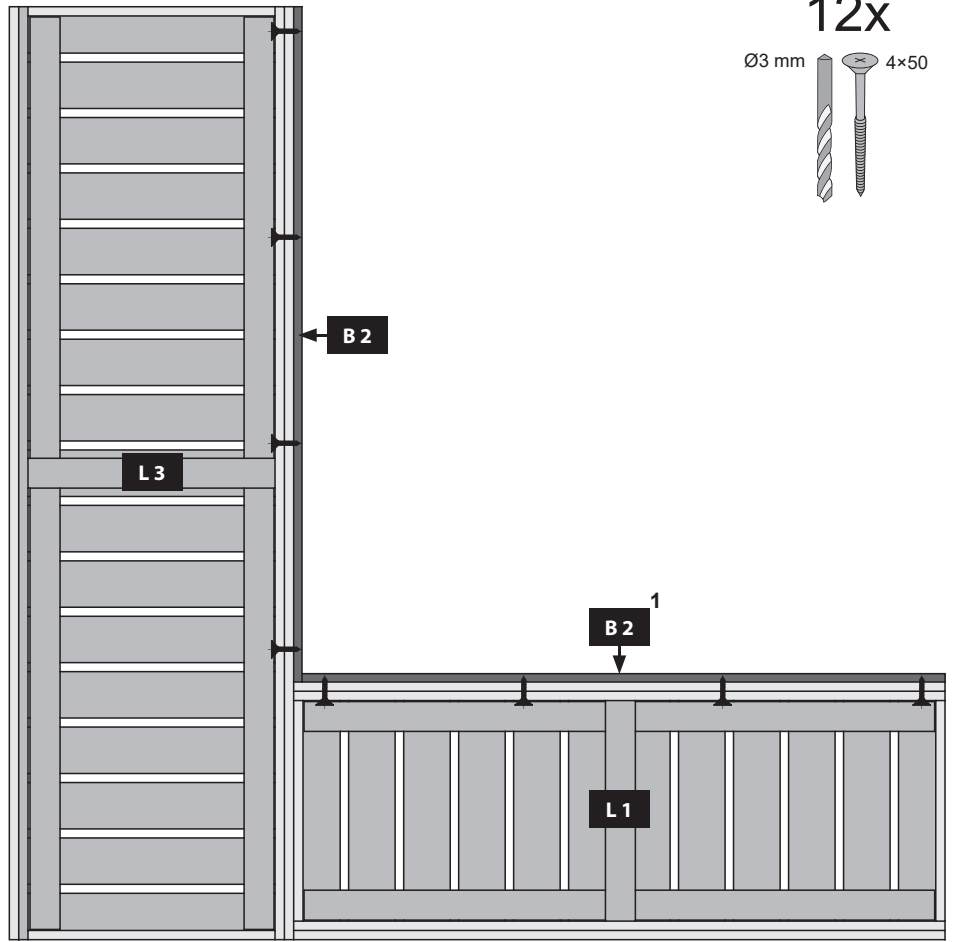
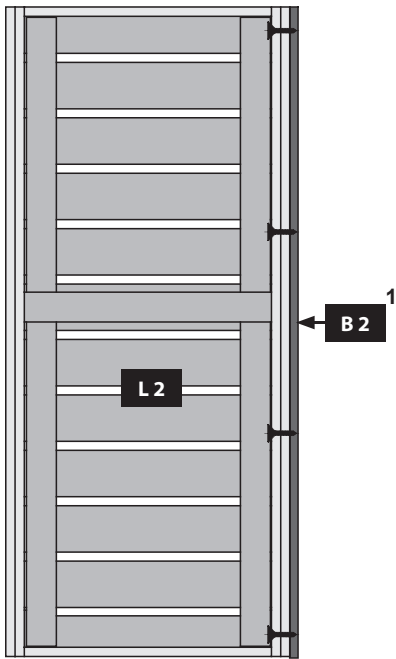
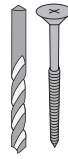

a



12x

Ø3 mm 4x30

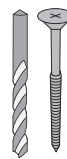

b

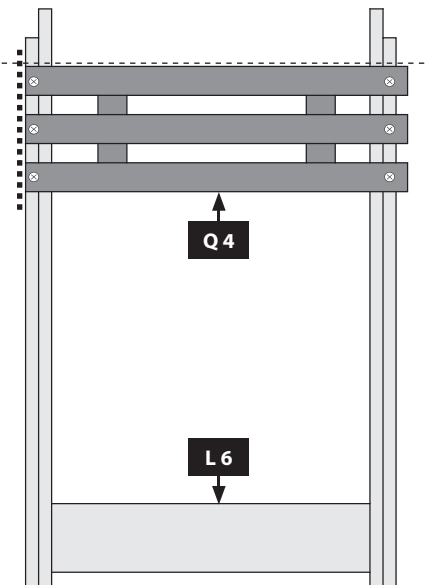
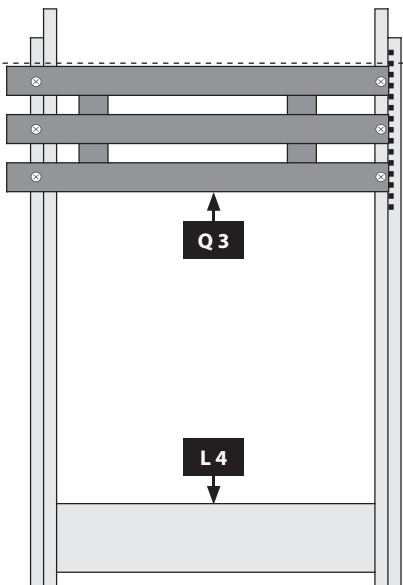
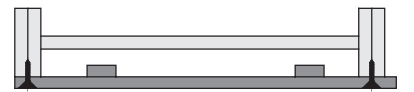

815 mm

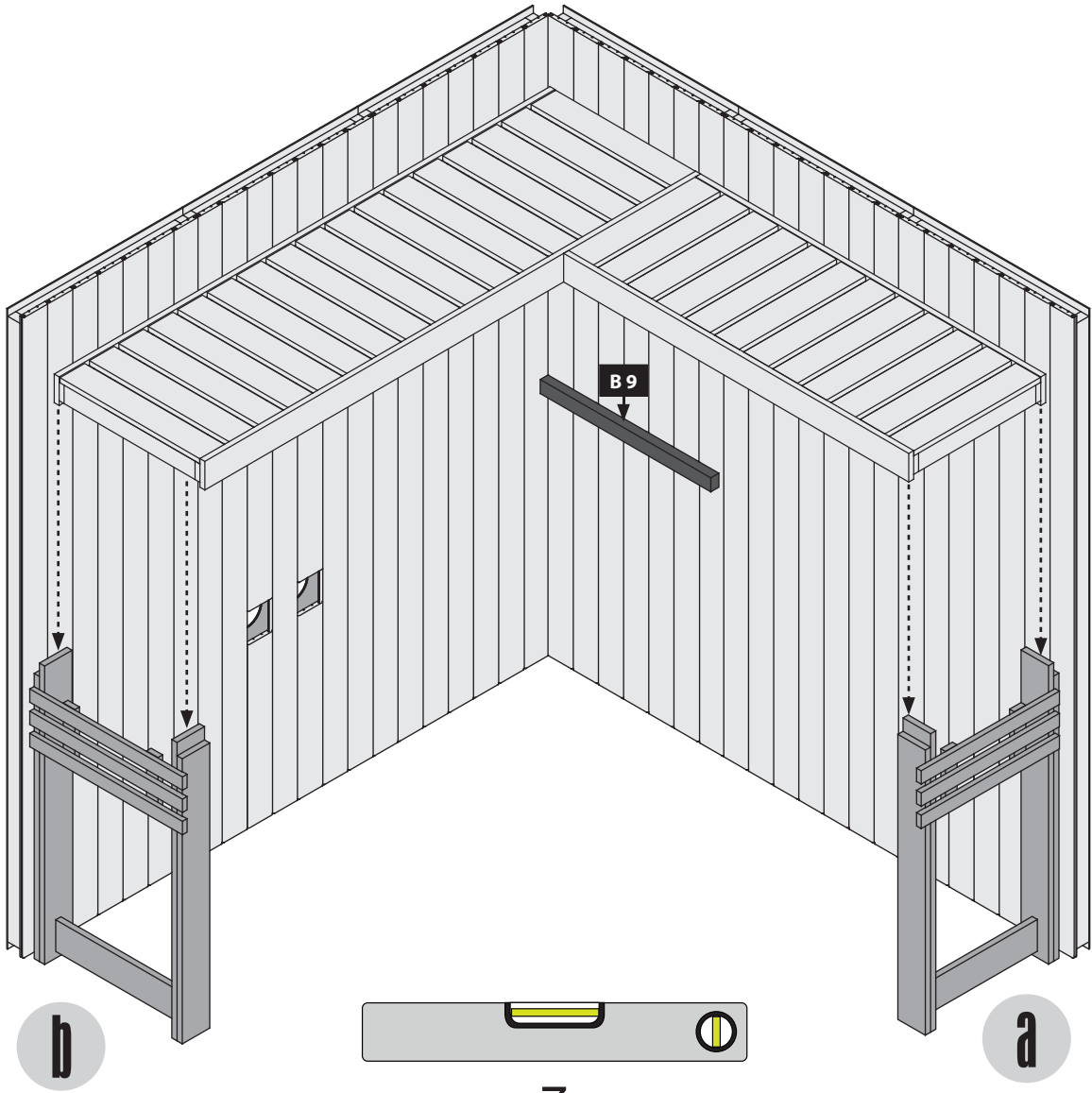

7x
Ø4 mm 4,5x80

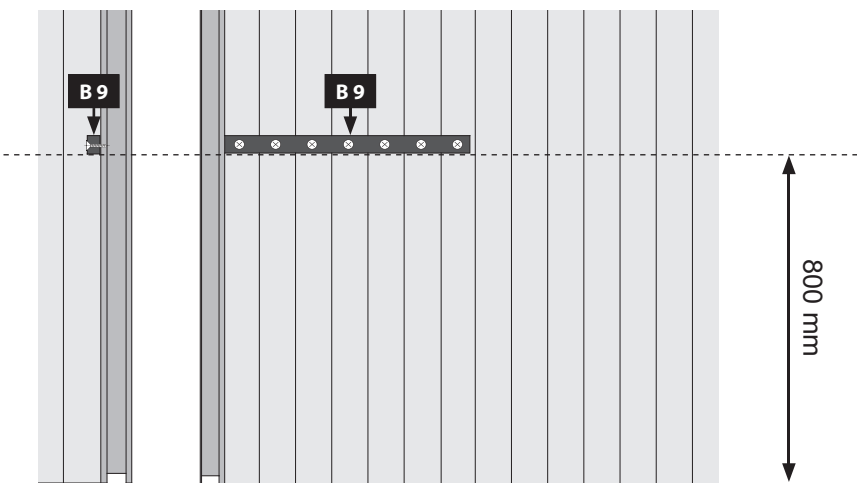

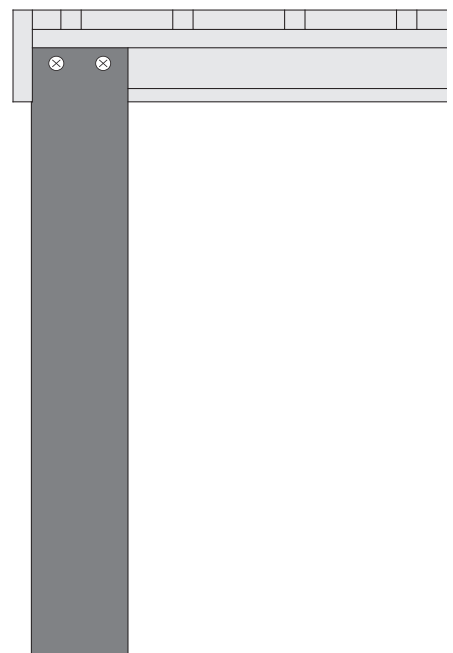
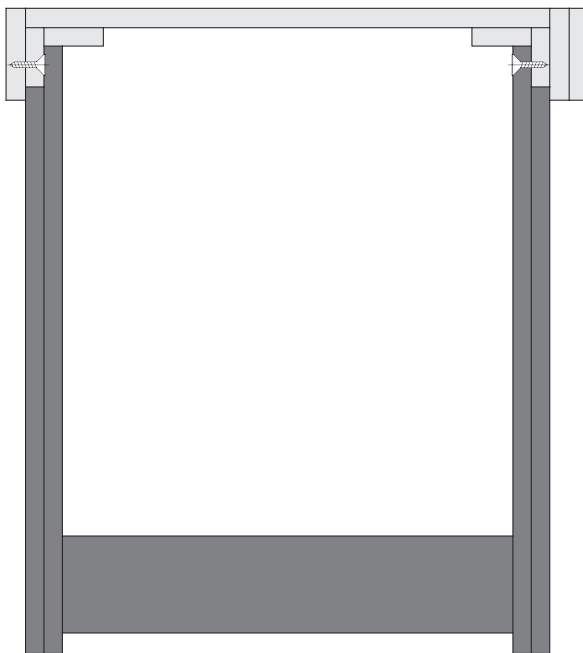
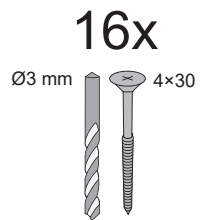
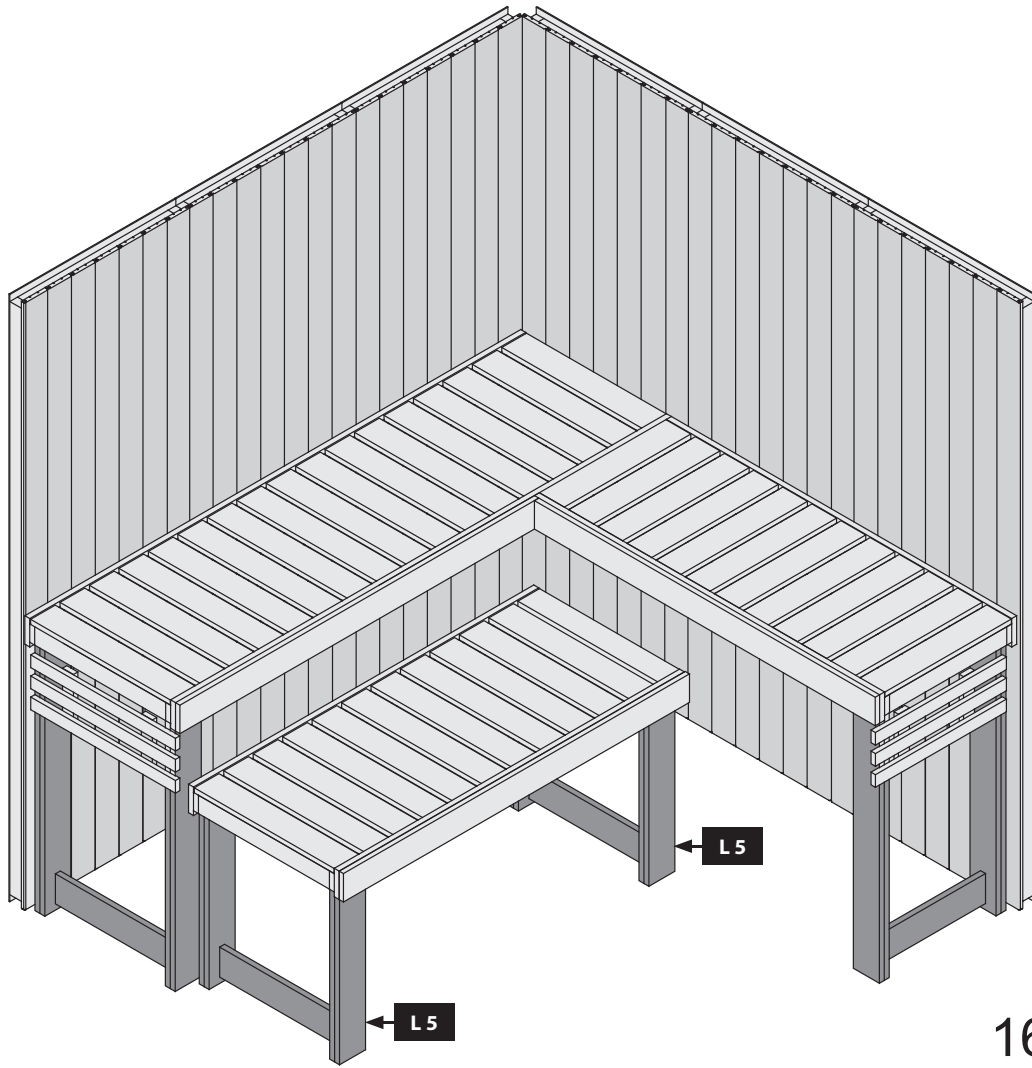

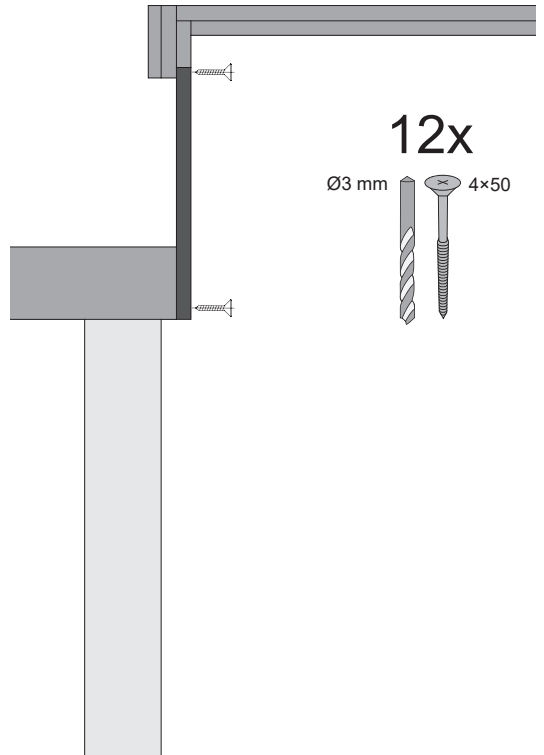
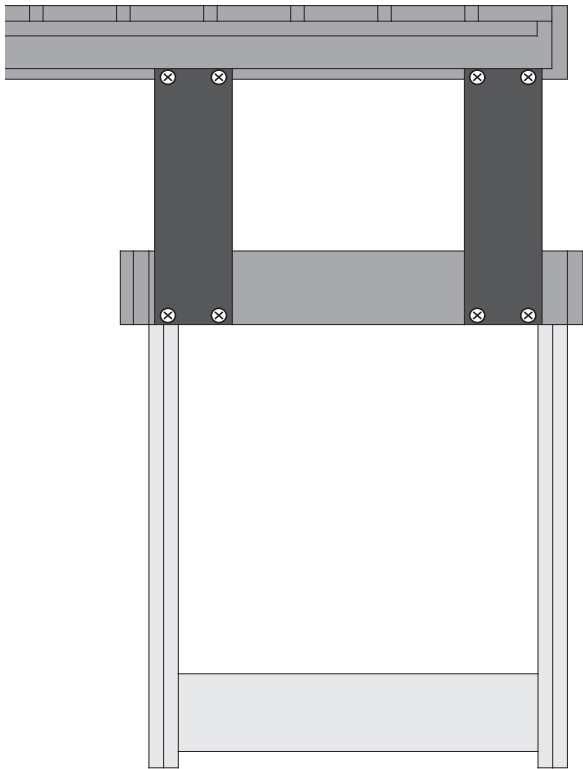
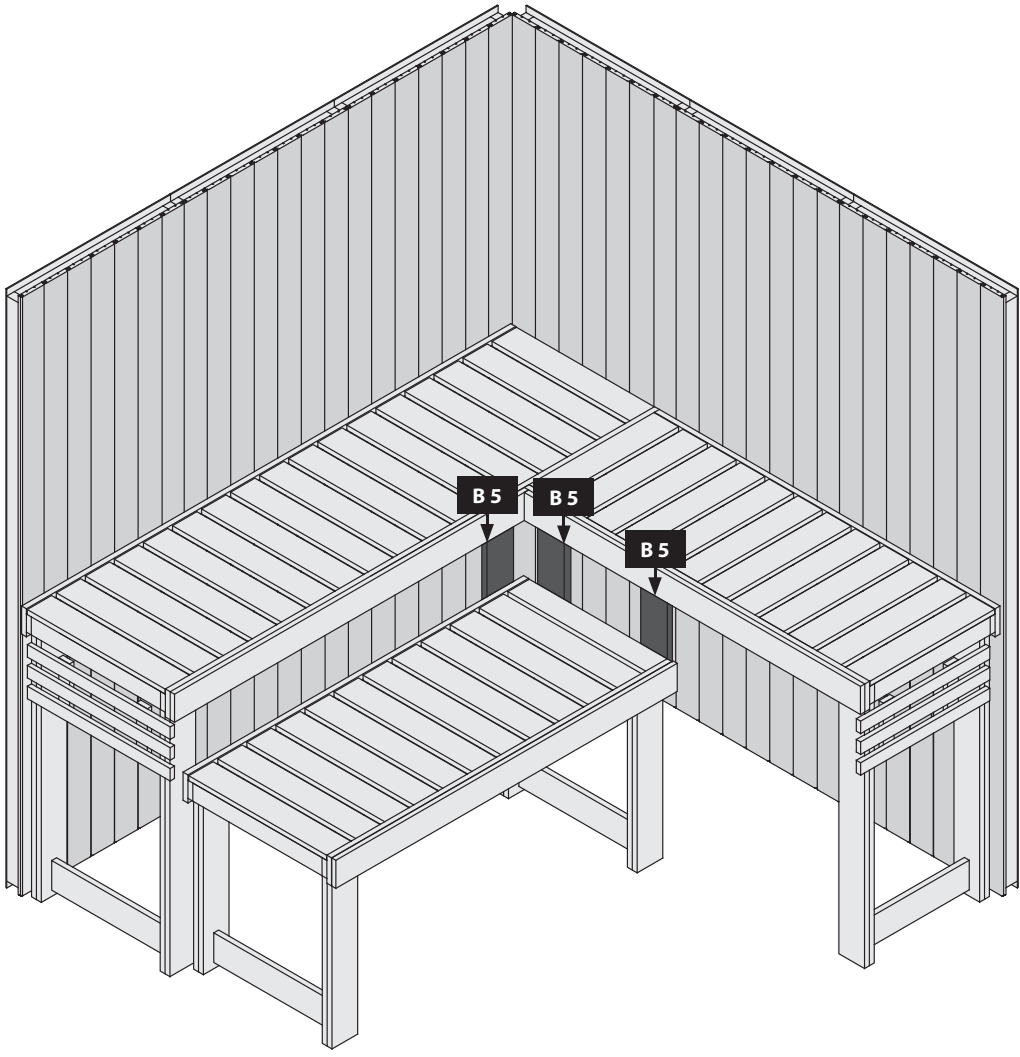

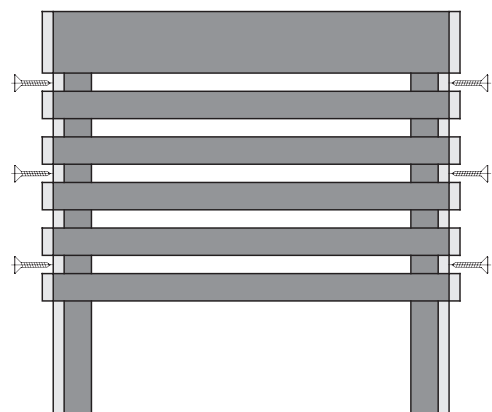
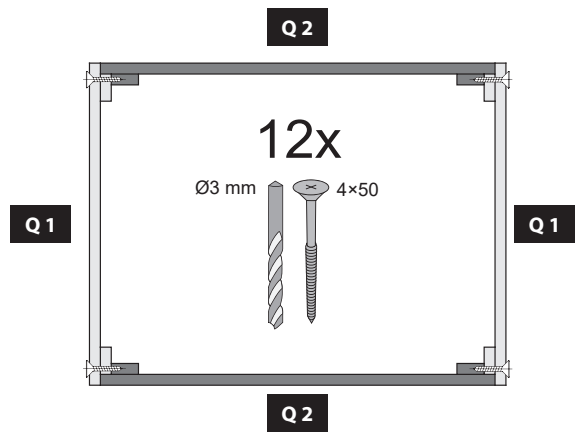
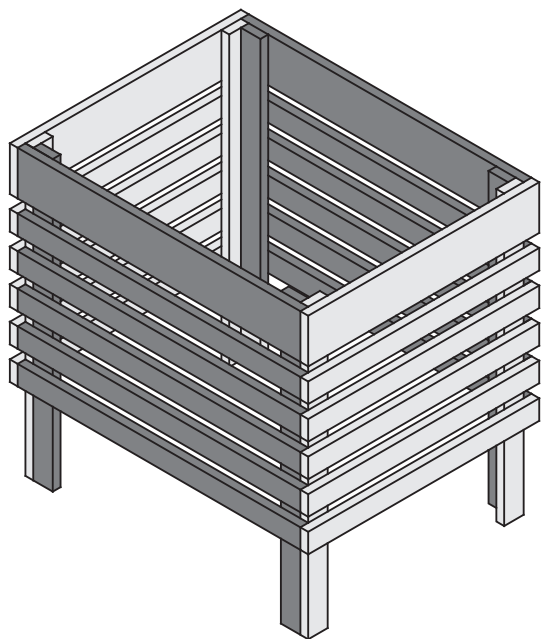
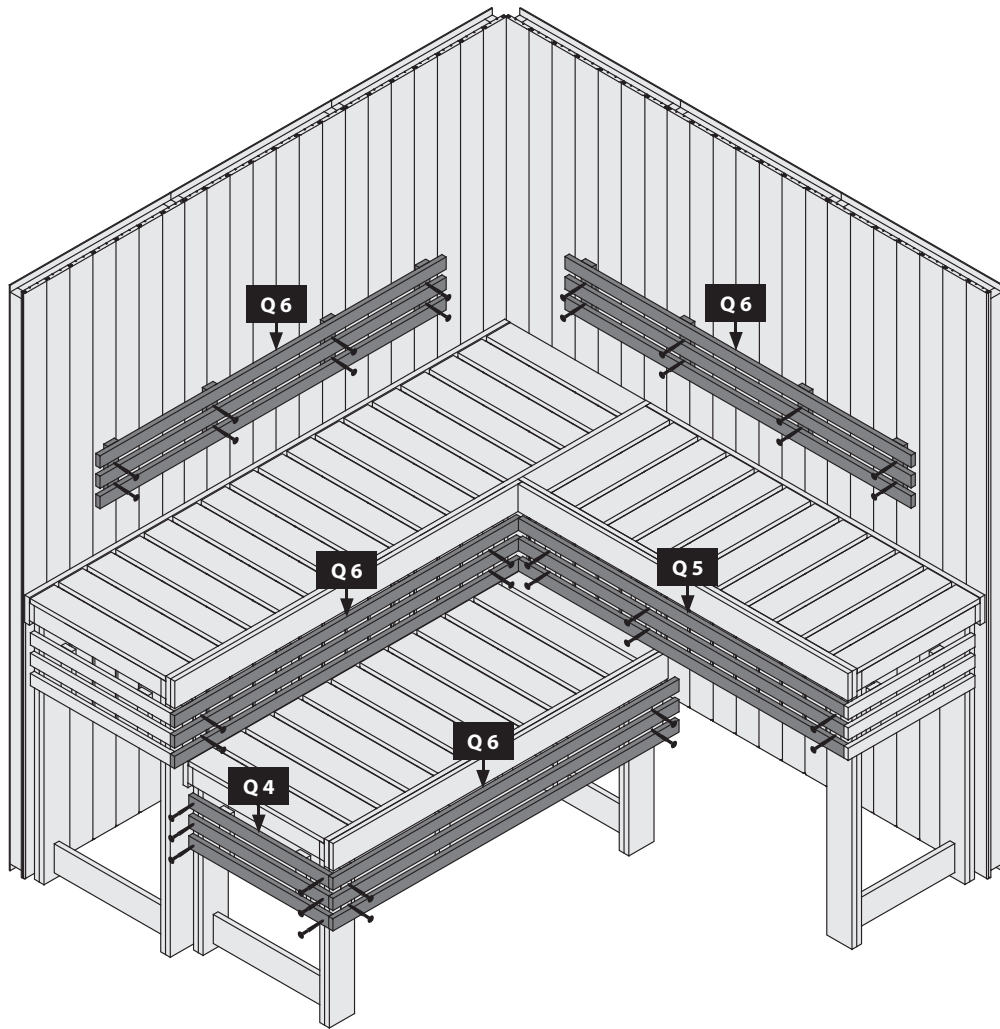

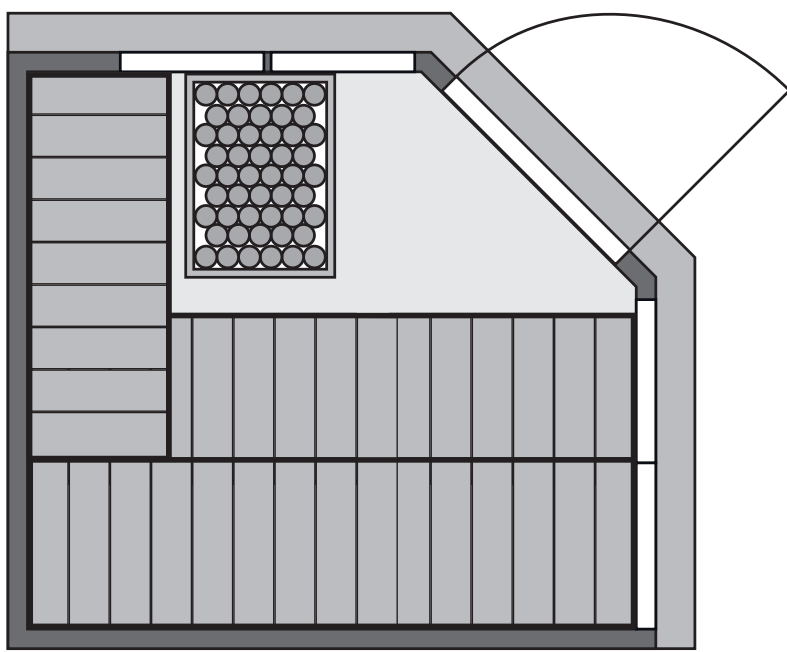
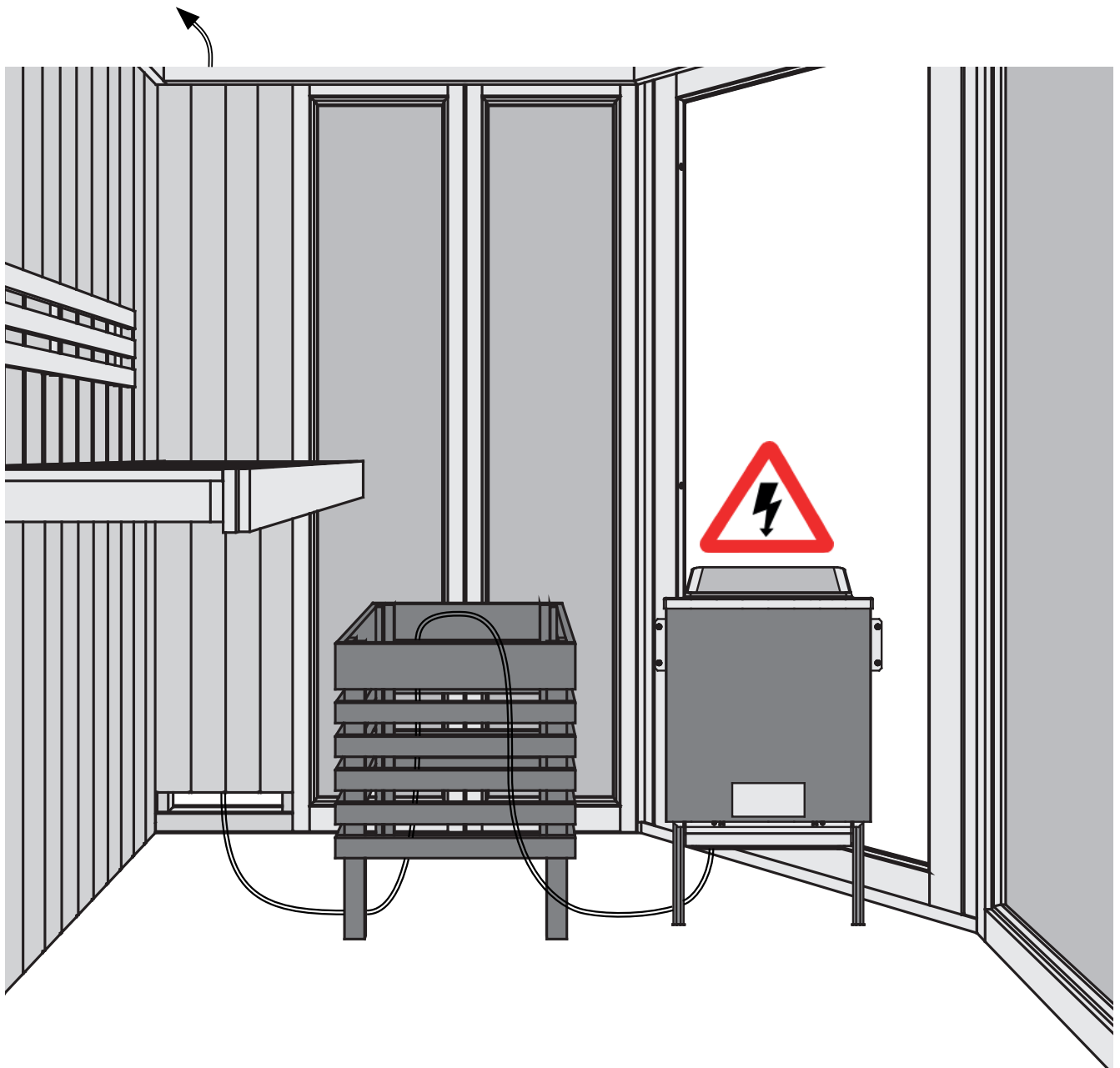





 Exemplarische Kabelverlegung

 Voorbeeld van het leggen van kabels

 Esempi di posa di cavi

 Exemplary cable laying

 Eksempel på kabellægning

 Příkladné pokládání kabelů

 Exemple de pose de câbles

 Tendido de cables ejemplar

 Vzorčno polaganje kablov

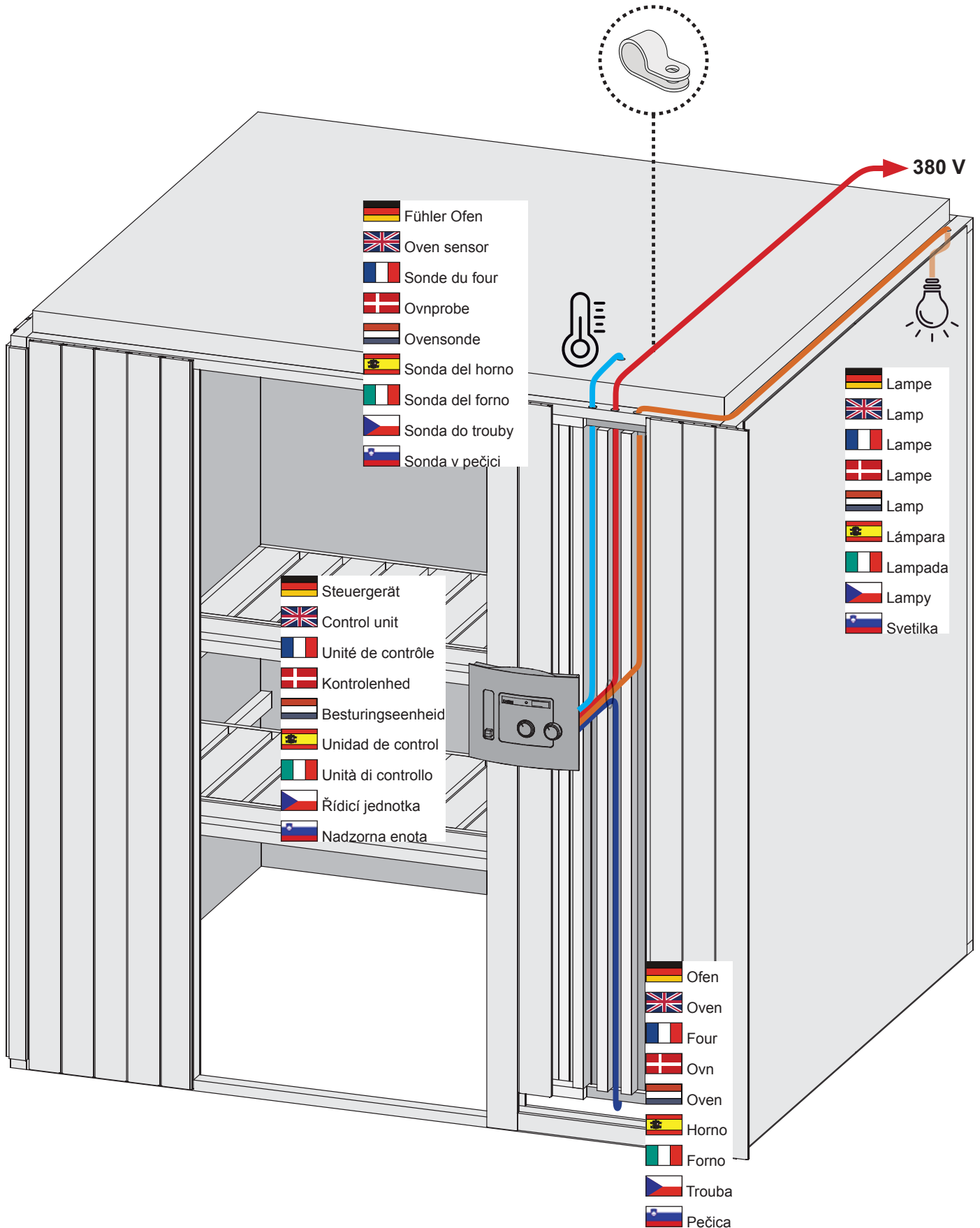
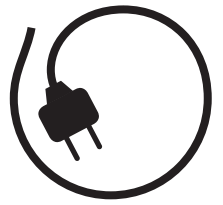



 Exemplarische Kabelverlegung

 Voorbeeld van het leggen van kabels

 Esempi di posa di cavi

 Exemplary cable laying

 Eksempel på kabellægning

 Příkladné pokládání kabelů

 Exemple de pose de câbles

 Tendido de cables ejemplar

 Vzorčno polaganje kablov

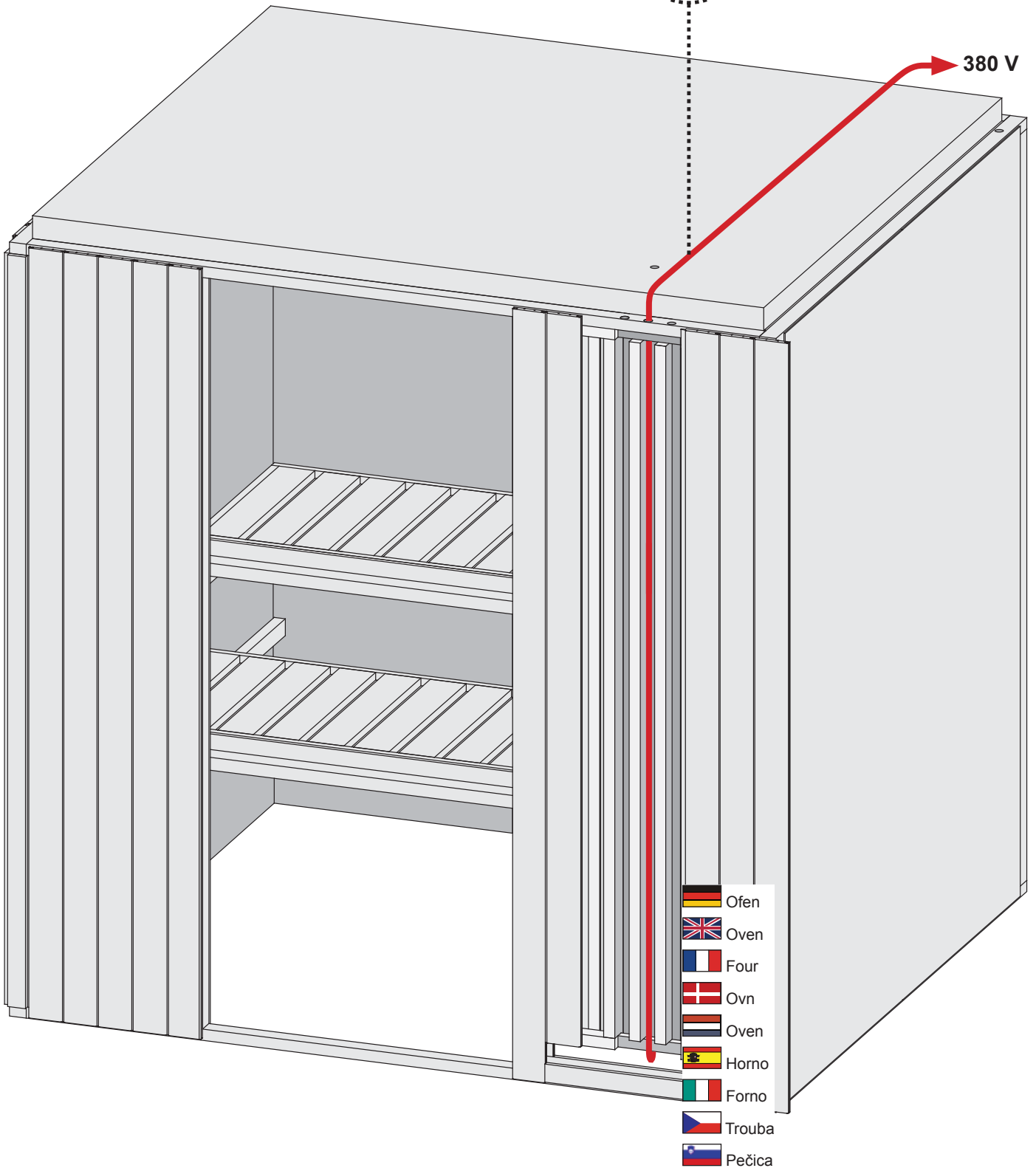
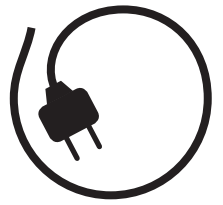

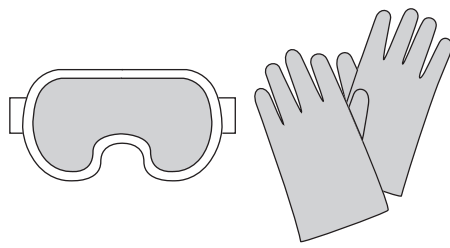



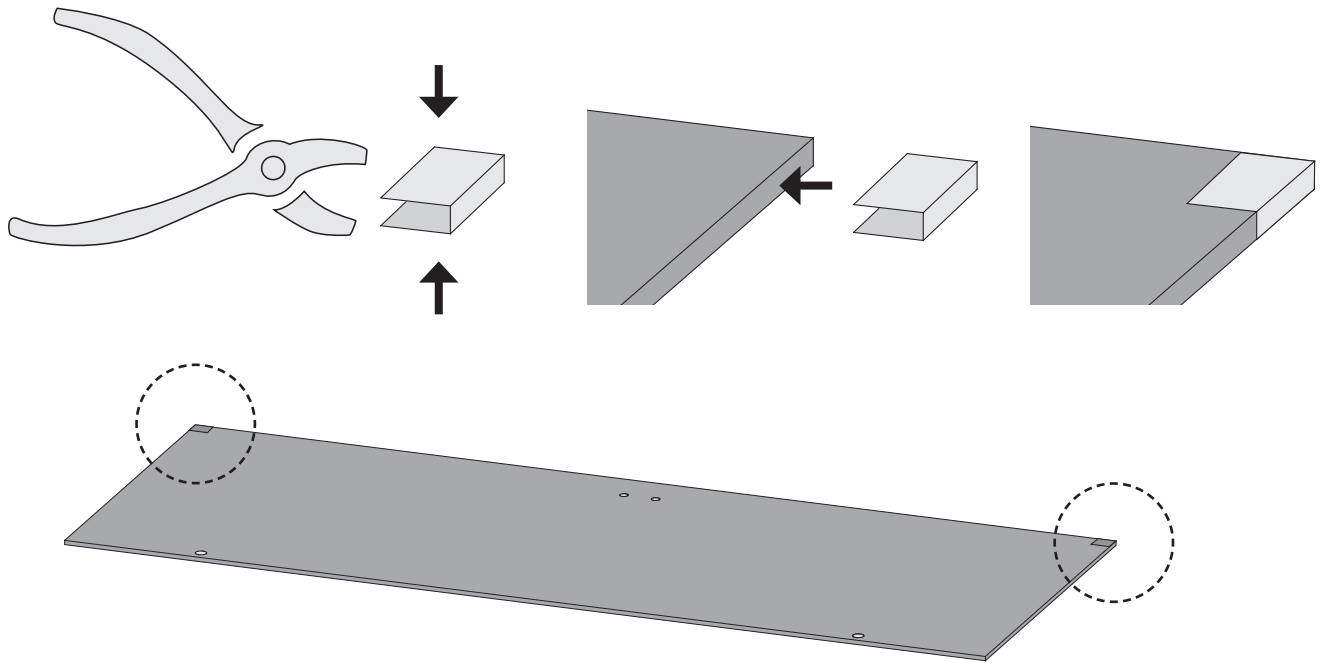



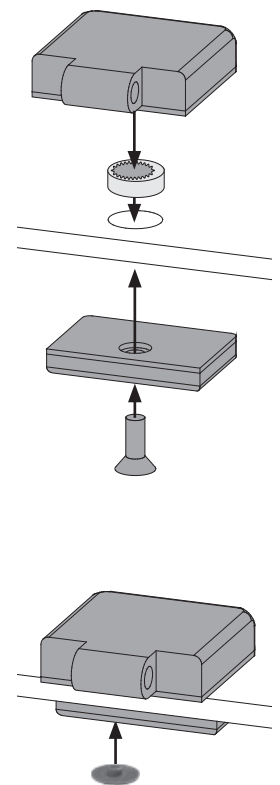
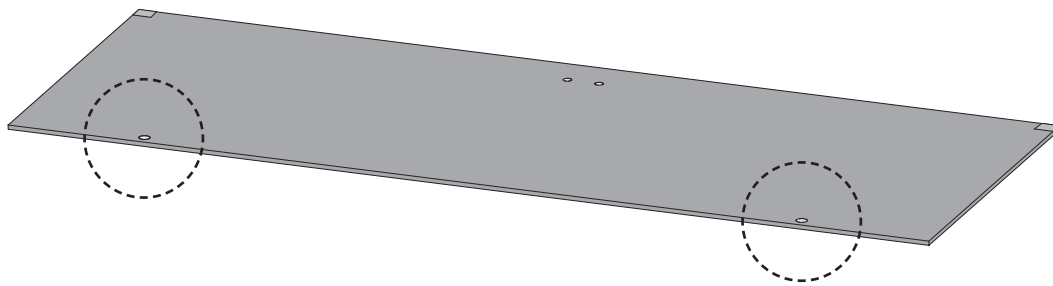



24









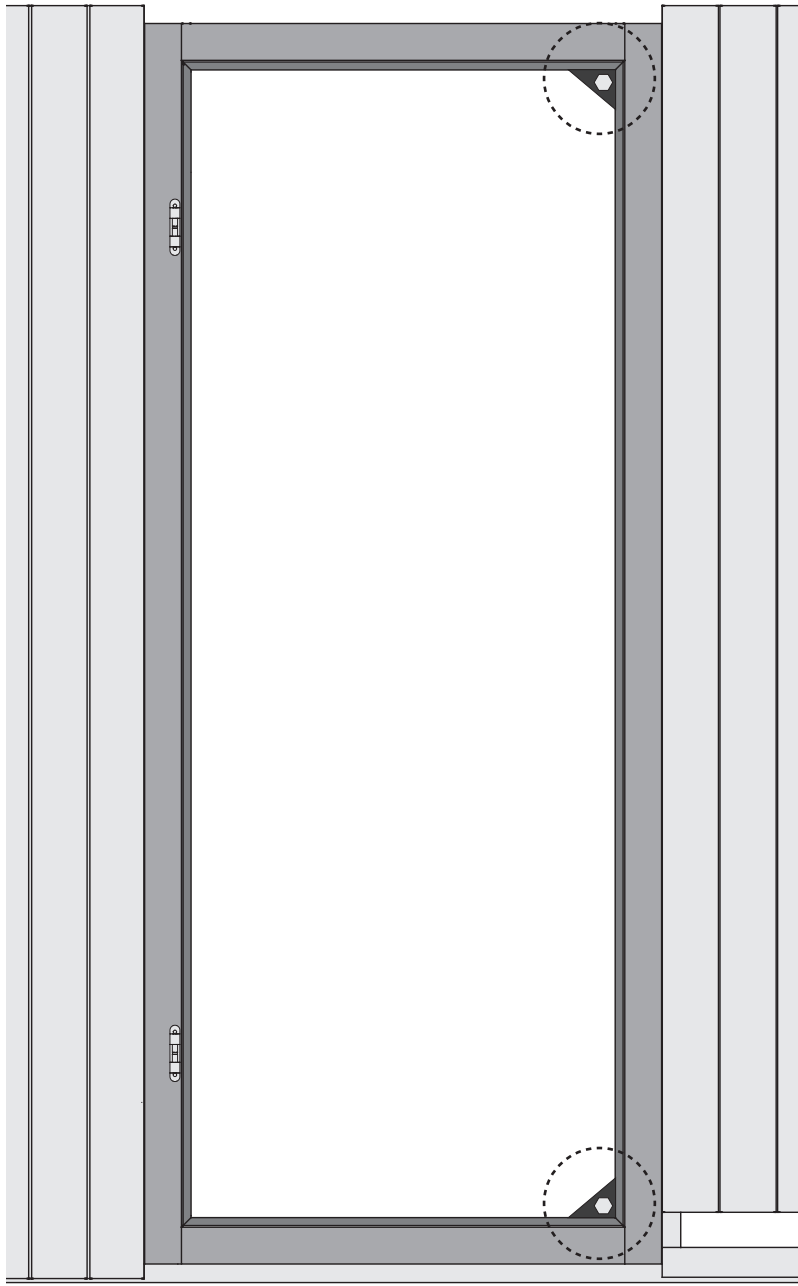
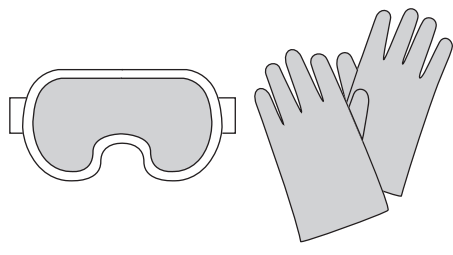

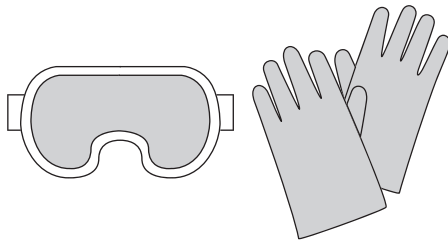

25



-  Alle Verstell-Excenter müssen in der Glasscheibe die gleiche Grundstellung haben
-  All adjustable eccentrics must have the same basic adjustment in the glass panel
-  Tous les excentreurs de positionnement doivent avoir la même position de base dans la vitre
-  Alle excentrische verstelelementen moeten in dezelfde stand in de glasplaat worden geplaatst
-  Alle justeringsexcenter skal have samme grundlæggende position i glasruden
-  Todos los excéntricos regulables tienen que tener la misma posición base en la hoja de cristal
-  Tutti gli eccentrici di regolazione devono avere la stessa posizione base nella lastra di vetro
-  šechny nastavovací podivínů musí mít stejný základní polohy ve skle
-  Vsi nastavivneni ekscentri morajo imeti enak osnovni položaj v steklu.





-  Alle Verstell-Excenter müssen in der Glasscheibe die gleiche Grundstellung haben
-  All adjustable eccentrics must have the same basic adjustment in the glass panel
-  Tous les excenteurs de positionnement doivent avoir la même position de base dans la vitre
-  Alle excentrische verstelelementen moeten in dezelfde stand in de glasplaat worden geplaatst
-  Alle justeringsexcentricer skal have samme grundlæggende position i glasruden
-  Todos los excéntricos regulables tienen que tener la misma posición base en la hoja de cristal
-  Tutti gli eccentrici di regolazione devono avere la stessa posizione base nella lastra di vetro
-  všechny nastavovací podivínů musí mít stejný základní polohy ve skle
-  Vsi nastavitveni ekscentri morajo imeti enak osnovni položaj v steklu.

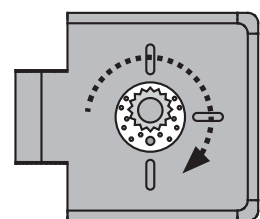
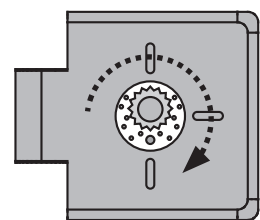
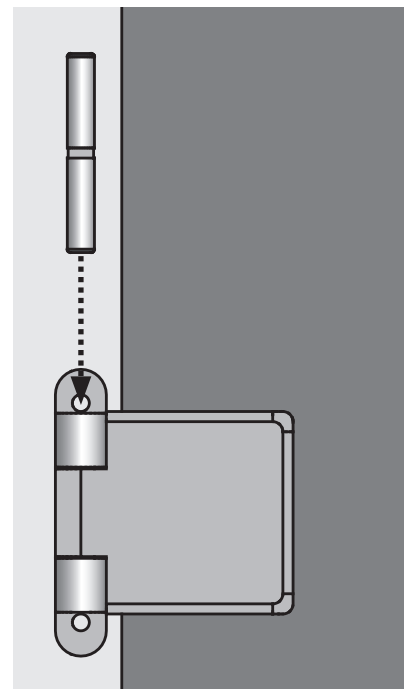
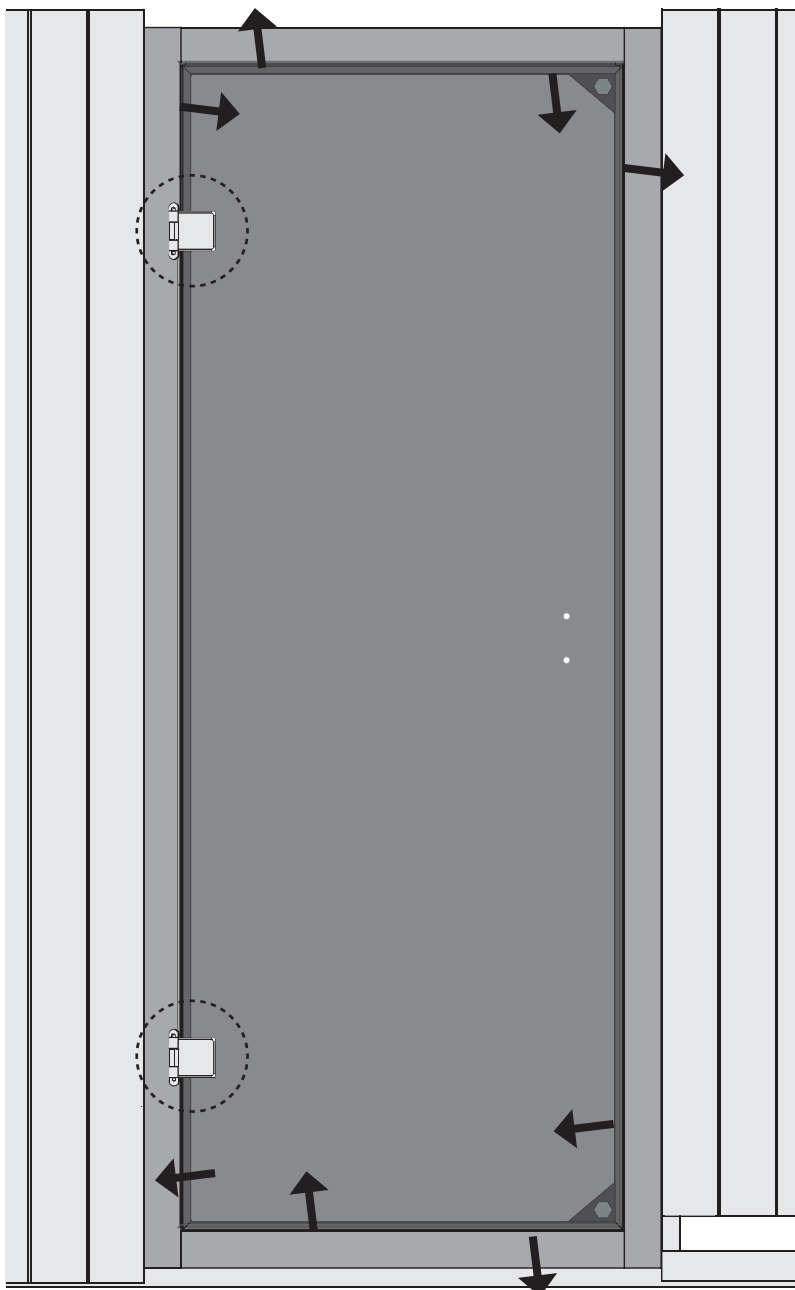

1.

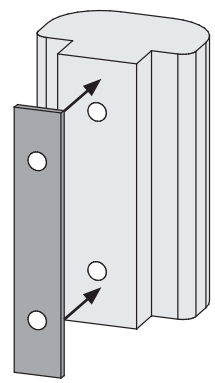

2.

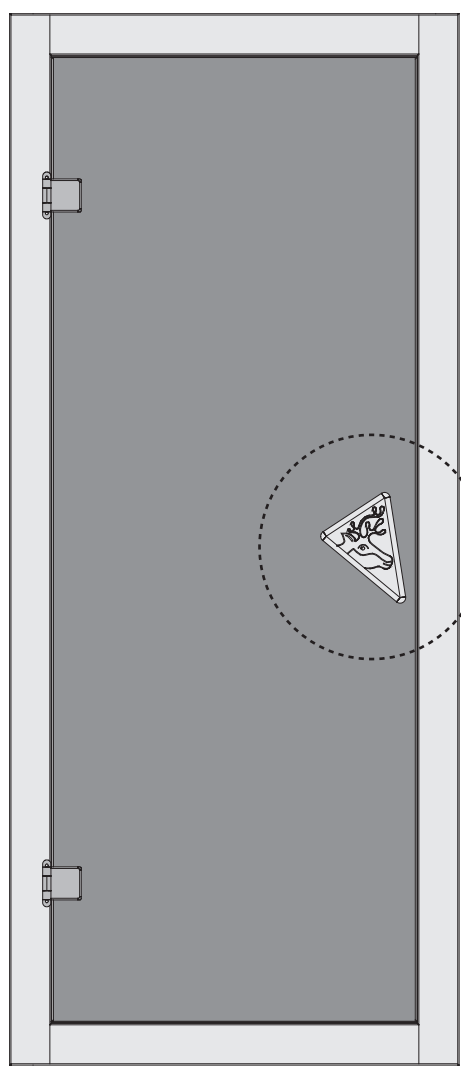
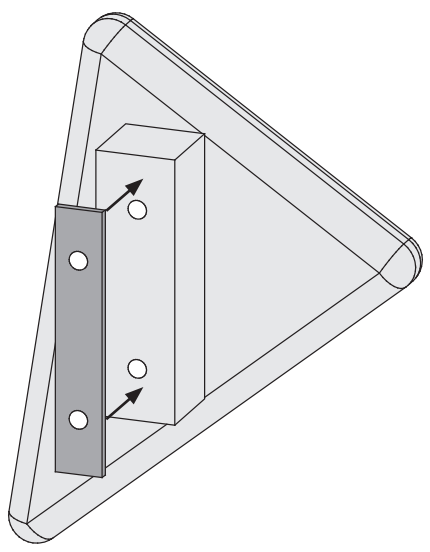

3.

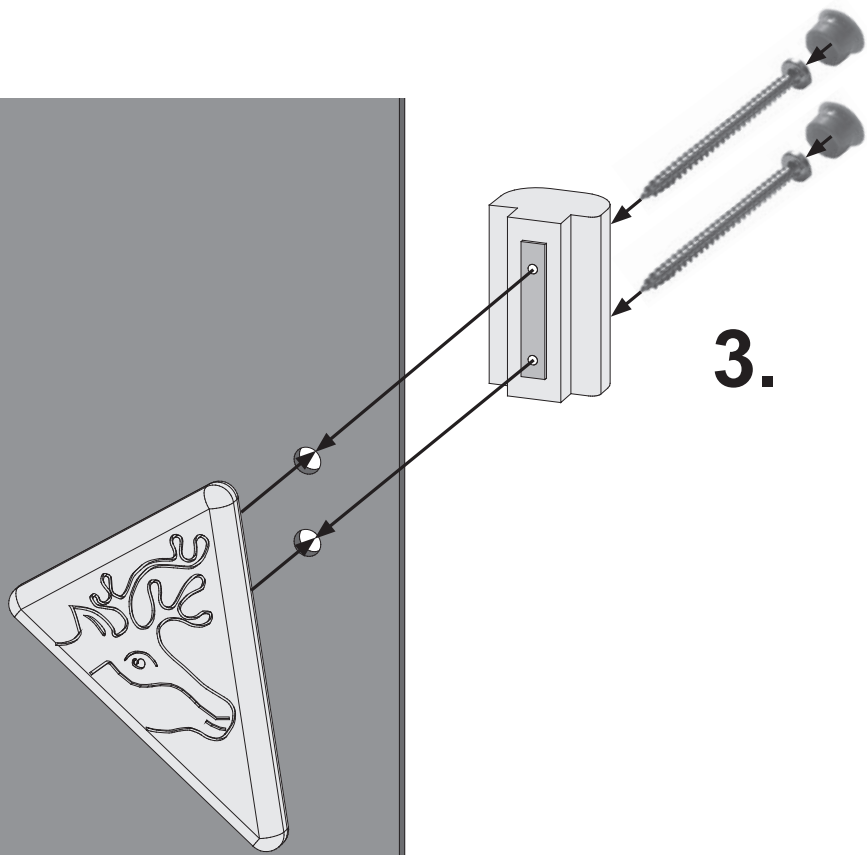

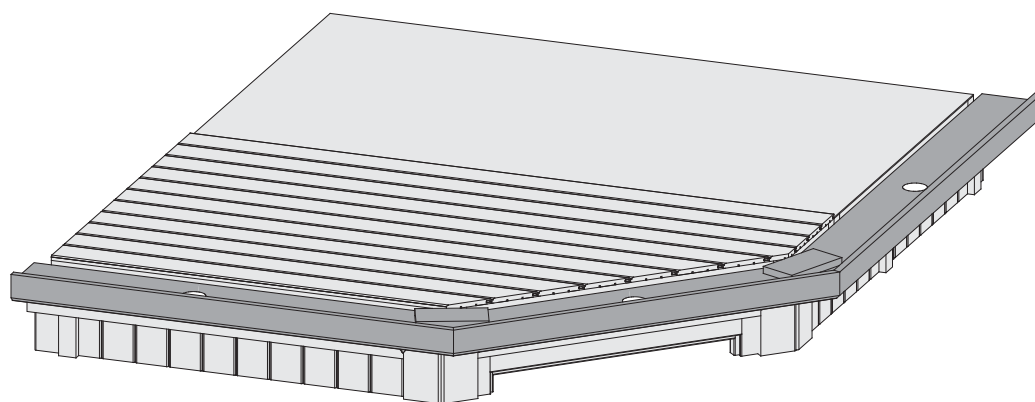

64227





-  **Aufbauanleitung**
-  **Building Instructions**
-  **notice de montage**
-  **montagehandleiding**
-  **Montagevejledning**
-  **Instrucciones de construcción**
-  **Istruzioni per il montaggio**
-  **Montážní návod**
-  **Navodila za sestavljanje**

 Vergleichen Sie zuerst die Material-liste mit Ihrem Paketinhalt! Bitte haben Sie Verständnis, dass Beanstandungen nur im nicht aufgebauten Zustand bearbeitet werden können!

 First compare the list of materials with your package contents! Please understand that complaints can be processed in the non-built status only!

 Commencez par comparer la liste du matériel avec le contenu de votre paquet! Sachez que nous traitons uniquement les réclamations concernant le matériel à l'état non monté!

 Vergelijk eerst de lijst van materialen met de inhoud van uw pakket! Reclamaties kunnen alleen in behandeling worden genomen zolang de onderdelen nog niet zijn gemonteerd!

 Start med at kontrollere materialelisten med indholdet af den leverede pakke! Vi gør venligst opmærksom på at reklamationer kun kan behandles for materialer som ikke er blevet bearbejdet!

 En primer lugar, compare la lista de material con el contenido del paquete. Rogamos entienda que las reclamaciones sólo pueden ser tramitadas antes de montar el objeto!

 Confrontate questa distinta materiali prima con il contenuto del pacchetto! Vi preghiamo di comprendere che eventuali reclami possono essere accolti solo prima del montaggio!

 Nejprve přezkontrolujte obsah balení podle materiálového listu! Mějte pochopení pro to, že případnou reklamaci se můžeme zabývat pouze tehdy, když díly nebudou smontované! Za pomoci tohoto seznamu můžete jednotlivé díly přiřadit k montážnímu návodu.

 Najprej primerajte zoznam materialov z vebino vašega paketa! Upoštevajte, da lahko pritožbe obravnavamo le v nesestavljenem stanju!

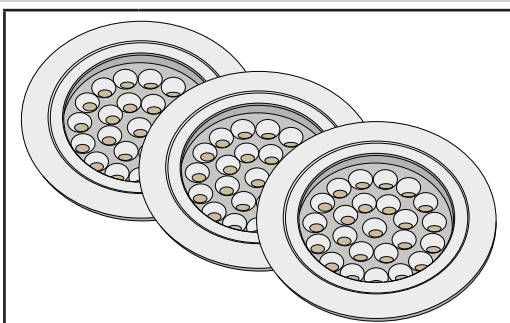
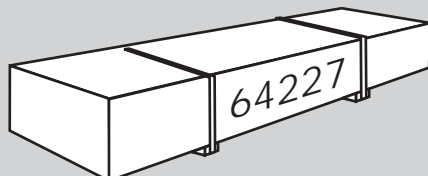

1 x ID 70565

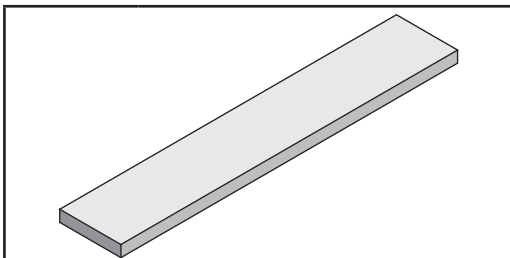

2 x A1 200 x 95 x 18mm ID 28440

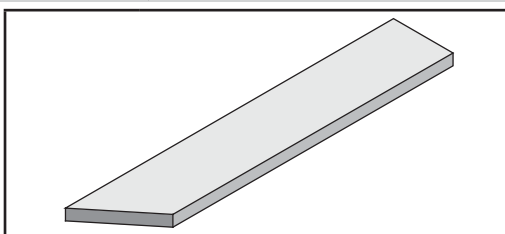

2 x B1 1730 x 140 x 26mm ID 47476

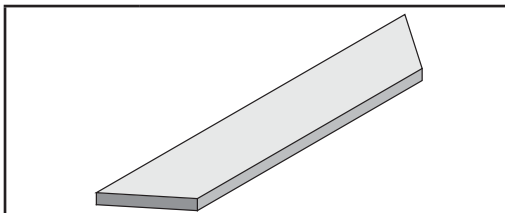

1 x C1 1045 x 140 x 26mm ID 21117

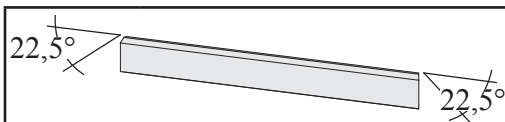

1 x D1 1060 x 58 x 18mm ID 47473

2 x D2 1790 x 58 x 18mm ID 64262

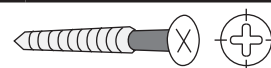

30 x 4 x 40 mm ID 21925

50 x 4 x 50 mm ID 3688

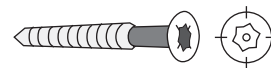

20 x 4,5 x 40 mm ID 26285

30 x ID 26116



01

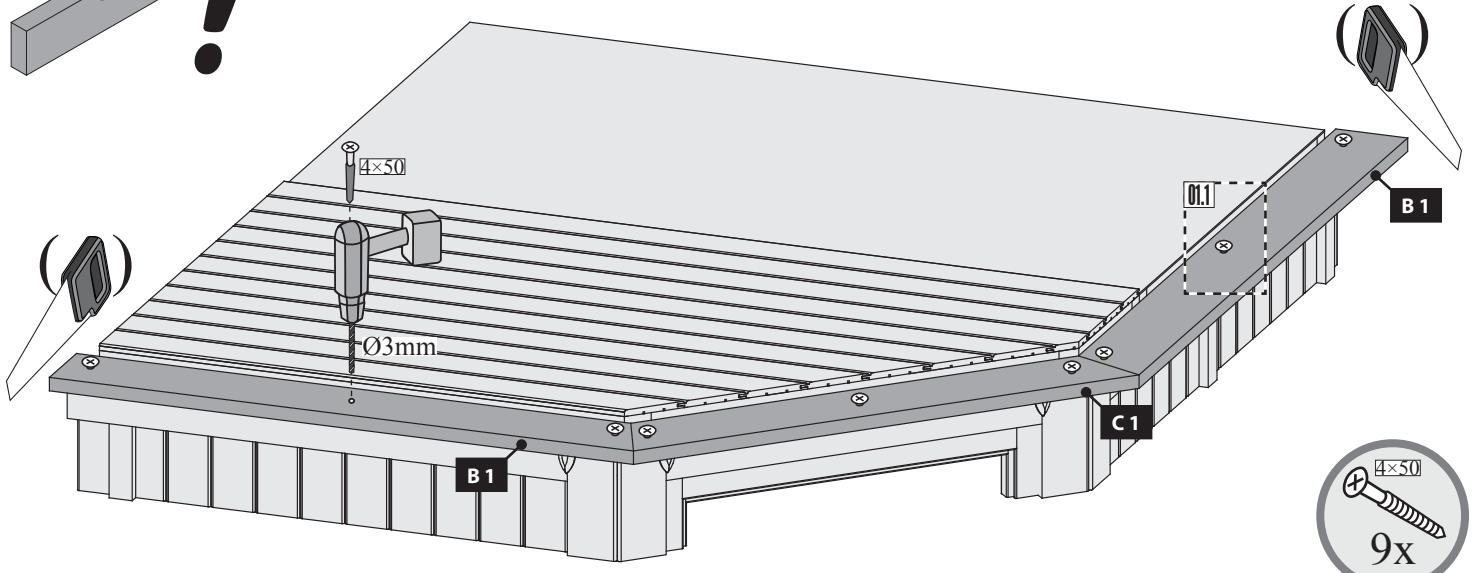
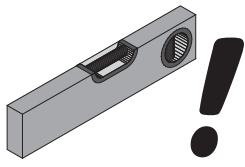

01.1

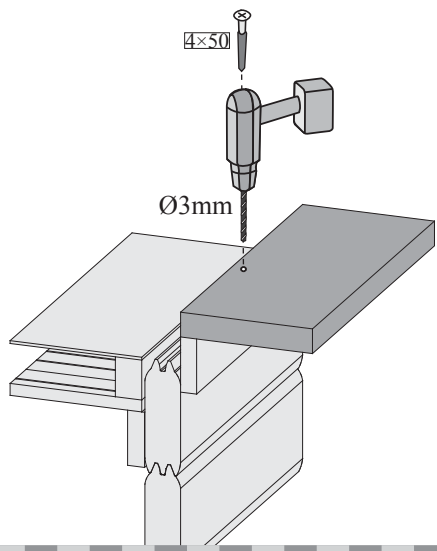

02.1

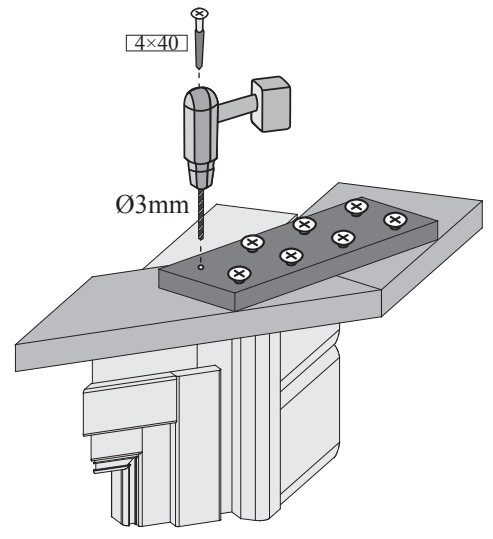

02

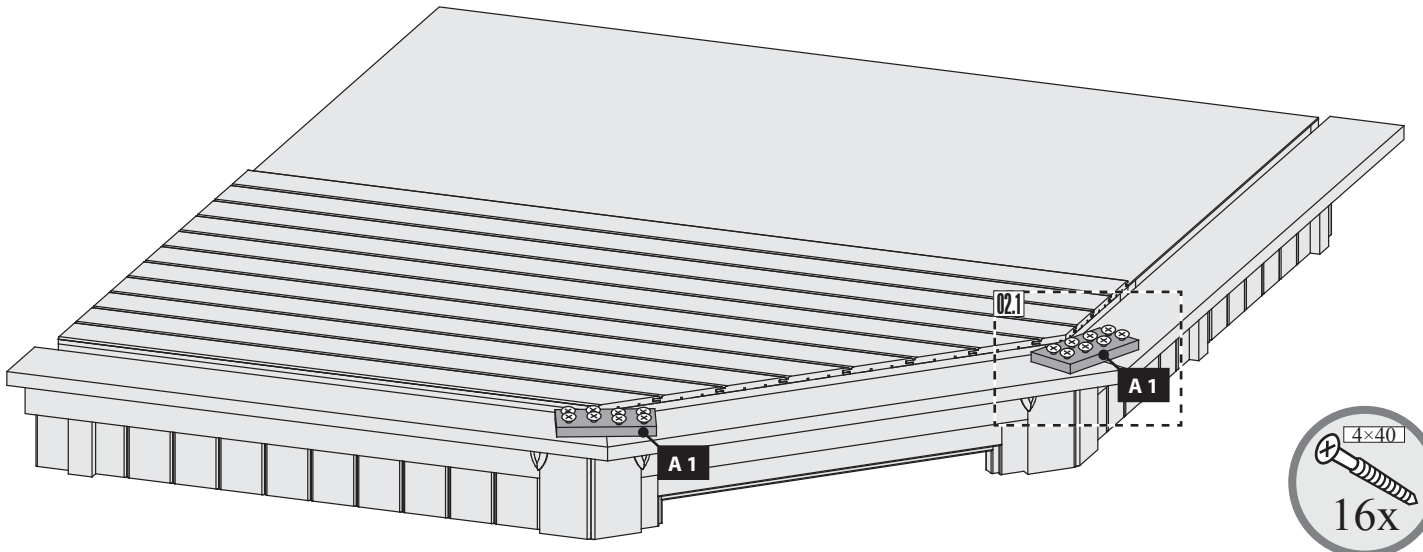

03

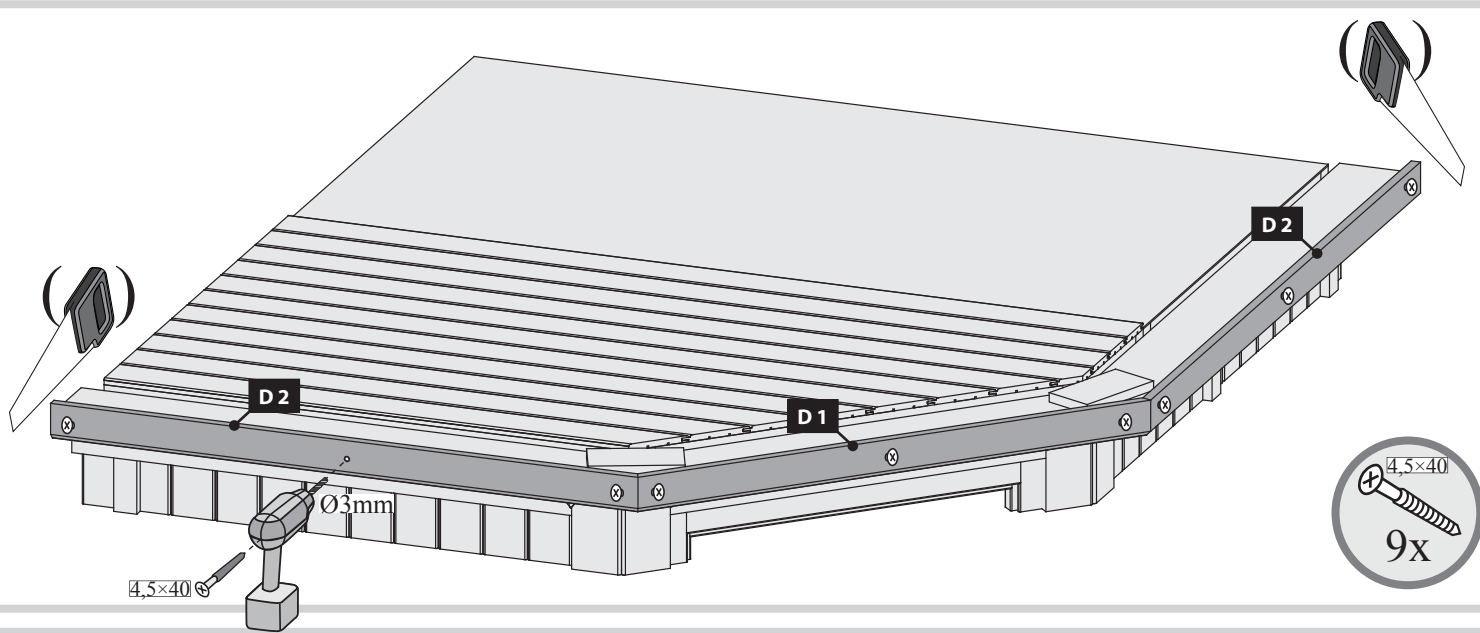

04

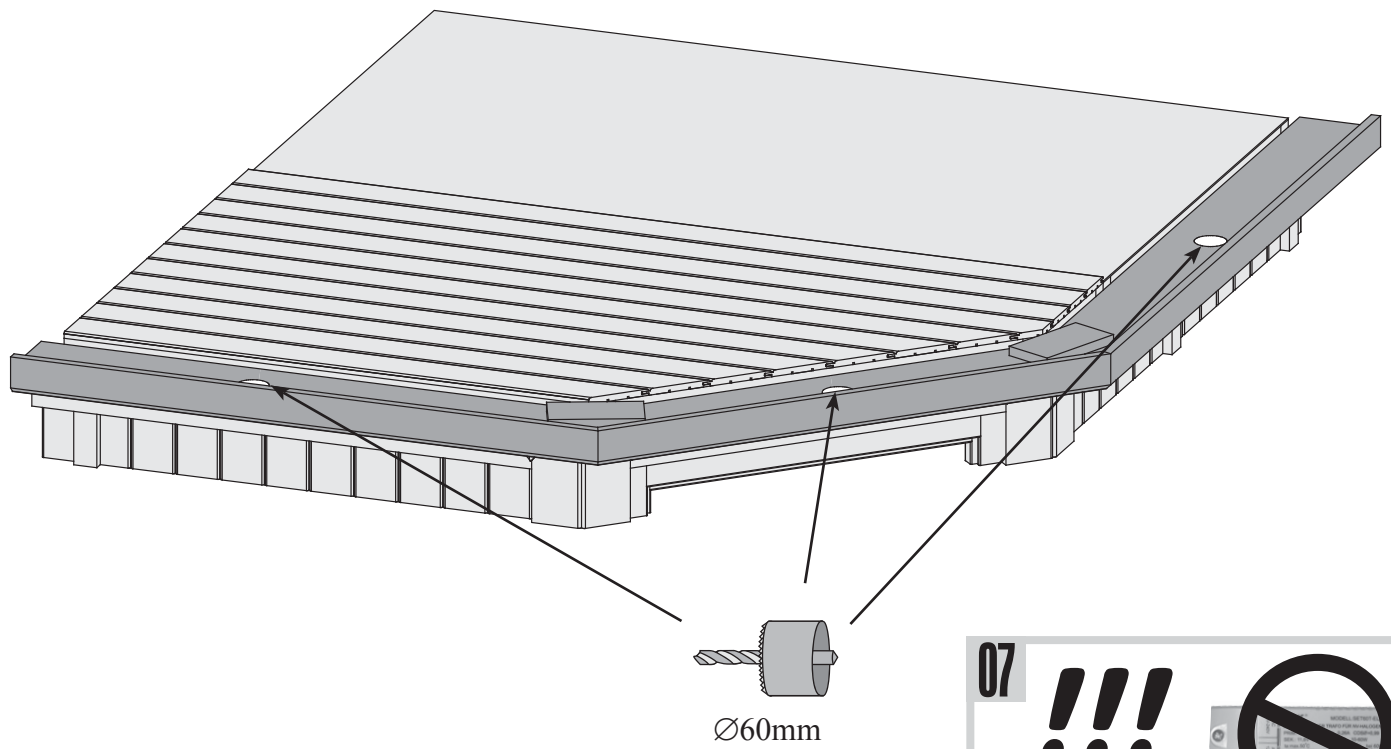

05

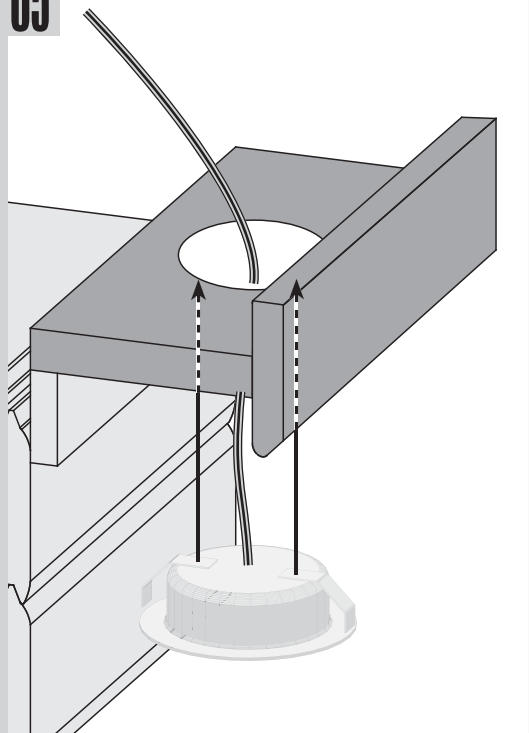

06



07

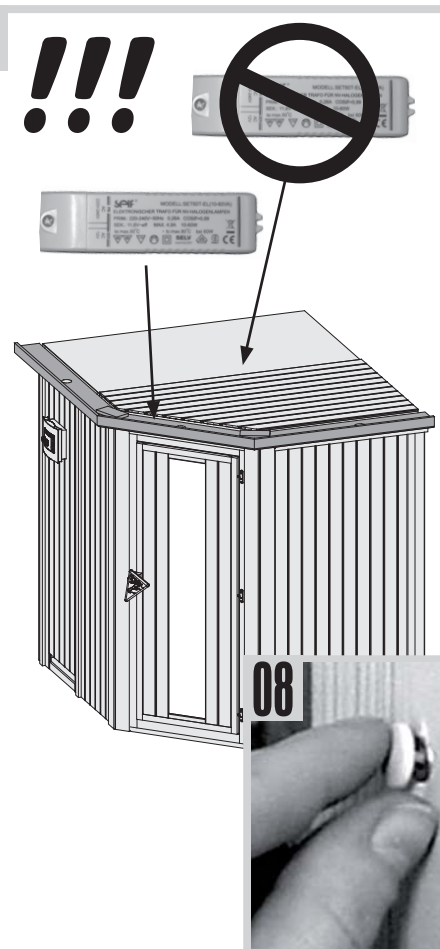

08

